

Salice Paolo

TIMELESS

EDIZIONE  
EDITION

02



Salice Paolo



## DAL 1937 / SINCE 1937

Paolo Salice crea la sua linea di maniglie classiche a cavallo degli anni 40-50, sfruttando il know how acquisito nella lavorazione dell'ottone nella sua officina meccanica.

Cantù e il suo territorio gli mettono a disposizione preziose risorse artigianali, tra cui disegnatori, intagliatori ed esperti cesellatori, per poter evolvere la gamma insieme al figlio Bruno. Tecnica, cultura e competenze artigianali si fondono oggi in una gamma completa per stili e finiture, posizionata nella fascia alta del mercato.

Nello storico stabilimento di Cantù, si alternano sistemi altamente automatizzati e lavorazioni manuali, con tecnologie di depurazione delle acque di processo e per l'aria conformi alle più recenti normative. L'installazione di vasche di sgrassaggio ad acqua elimina totalmente l'uso di solventi, persino quelli attualmente dichiarati non dannosi. Giunta alla sua terza generazione, la famiglia Salice guida il marchio verso una costante evoluzione, nel rispetto della sua non comune tradizione e in difesa di una produzione genuinamente made in Italy.

*During the 1940s and 50s, Paolo Salice created a classic handles range exploiting the brass working knowledge he acquired in his mechanical workshop.*

*Cantù and its region, located between Milan and Lake Como, provided him with precious craft resources, including designers, carvers and expert engravers, which helped him and his son, Bruno to develop the range.*

*Technique, tradition, and artisanship combine in a complete range of styles and finishes, positioned at the high-end of the market. At the historic Cantù plant, highly automated and manual processing systems alternate with process water and air purification technologies that are compliant with the latest regulations.*

*Water-based degreasing tanks eliminate solvents - even those declared "safe" by today's standards.*

*Now in its third generation, the Salice family is a guardian of a genuinely Made in Italy product and leads the brand towards constant evolution while respecting its rare tradition.*



Ogni prodotto Salice Paolo è disegnato, realizzato e rifinito in Italia con alti standard di qualità.  
*The whole Ento production is designed, made and finished in Italy with high quality standards.*





## LA GAMMA TIMELESS / *THE TIMELESS RANGE*

Con la gamma Timeless, Salice Paolo offre una selezione di maniglie e accessori con la stessa qualità del catalogo Classico, realizzati interamente in ottone, controllati uno ad uno lungo tutto il processo produttivo. Nasce per un'idea di stile più sobrio, facile da inserire in ambienti molto diversi, incredibilmente versatile e contemporaneo.

*The Salice Paolo Timeless range offers a selection of handles and accessories with the same quality of the Classic catalogue, made entirely of brass, checked one by one throughout the production process. Born from an idea to have a more sober style, easy to combine in many different environments, extremely versatile and contemporary.*

La gamma viene presentata ufficialmente in concomitanza con il Salone del Mobile del 2017. Davide Diliberto progetta uno speciale allestimento che ne evidenzia la versatilità estetica attraverso l'abbinamento con numerose essenze di legni.

*The range has been unveiled in 2017, during the Salone del Mobile. The special booth designed by Davide Diliberto is intended to show all the versatile style side-by-side with various wood veneers.*





La nostra linea più versatile.

I modelli TIMELESS Salice Paolo hanno disegni e finiture pensati per abbinarsi facilmente a una gran varietà di stili ed essenze. Sono il complemento ideale per ambienti che spaziano dal Classico al Contemporaneo, passando da tutte quelle sfumature senza tempo tra cui il Déco, il Country, l'Etnico e l' Industrial.

*Our most versatile range.*

*The TIMELESS Salice Paolo models have designs and finishes to be easily combined to a wide variety of styles and woods. They are the ideal complement for environments ranging from classic to contemporary, from all those timeless shades including Deco, Country, Ethnic and the Industrial atmospheres.*

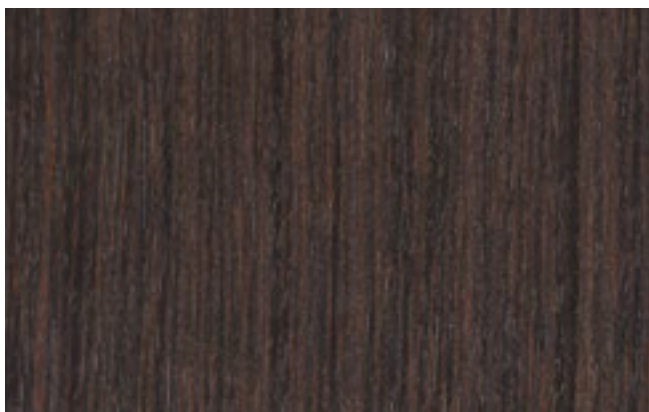



## UN MONDO CLASSICO CHE SI EVOLVE AN EVOLVING WORLD OF CLASSIC STYLE

Salice Paolo propone una gamma completa di elementi ed accessori in grado di arredare un ambiente in modo completo e di rispondere a tutte le esigenze pratiche ed estetiche dei suoi clienti.

*Salice Paolo offers a complete range of elements and accessories to fully furnish any environment and respond to customers' practical and aesthetic needs.*

Il catalogo completo si compone di:

*The complete catalogue consists of:*

- Maniglie
- Maniglie incasso
- Cremonesi e Dreykipp
- Maniglioni
- Pomoli
- Maniglie per mobili
- Accessori

- *Door handles*
- *Flush handles*
- *Window handles and Dreykipp*
- *Pull handles*
- *Door knobs*
- *Handles for furniture*
- *Accessories*



TUDOR, un esempio di gamma estesa. (Prodotti non in scala)  
*TUDOR, an example of extensive range. (Products not to scale)*

Tutti i modelli Salice Paolo sono disegnati in house.  
L'azienda si avvale anche di collaboratori di grande esperienza nel settore del mobile classico e di designer come Itamar Harari che offrono la loro visione alternativa in un campo tradizionale ma in continua evoluzione.  
Un concetto chiave della filosofia Salice Paolo.

*Every Salice Paolo product is designed in-house.  
The Company collaborates also with several professionals with a solid experience into the classic furniture sector; designers like Itamar Harari give their precious and different vision to keep innovating even in such a traditional market.  
This is a key point of the salice Paolo's philosophy.*

# LO STRUMENTO CORRELATI COORDINATION TOOL

Sul sito Salice Paolo ogni scheda prodotto presenta un sistema visivo e immediato per verificare tutte le possibilità per il vostro progetto, mostrando gli accessori della stessa famiglia o compatibili.

*On the website each product sheet contains a visual and immediate system for all your project's possibilities. It shows all the accessories in the same or a compatible range.*

**Facilitare la scelta per progettisti e clienti.**  
*Making designers and clients' choice easier.*







# QUALITÀ / QUALITY

La qualità senza compromessi del vero Made in Italy: dall'idea alla progettazione, dagli stampi alla finitura e controlli su ogni singolo pezzo.

*The uncompromising true Made in Italy quality: ideas, designs, moulds, finishing and checks on every piece.*



Le maniglie Salice Paolo sono testate per oltre 500.000 cicli di utilizzo. La molla di ritorno e tutti i componenti meccanici di alta qualità consentono una funzionalità costante per tutta la durata del prodotto.

*Salice Paolo door handles are tested for more than 500.000 cycles of use. The return spring and all the high quality mechanical components allow constant functionality along the entire life of the product.*

## VETRO E CRISTALLO

Tutti i prodotti con parti in vetro e cristallo sono testati per resistere ai carichi di flessione previsti.

## GLASS AND CRYSTAL

*All products with glass and crystal parts are tested to withstand the expected bending loads.*



Molla di ritorno  
*Return spring*



Lunghezza su richiesta  
*Custom measure on request*



Cristallo  
*Crystal*



Vetro  
*Glass*



Sull'etichetta di ogni confezione è riportato il codice Trace Me Code che consente di verificarne online l'autenticità.  
*Trace Me Code is on every packaging label, allowing the customer to verify online that the purchase is genuine.*



Tutta la gamma è realizzata in ottone, il miglior materiale per garantire finiture prive di difetti, alta resistenza agli agenti chimici e atmosferici e, non ultimo, per la massima sensazione di peso e solidità alla presa.

*The whole range is made of brass which is the best material to guarantee finishes without defects, high resistance to chemical and atmospheric agents and the maximum sensation of weight and firmness to the grip.*



Controllo su ogni pezzo in tutte le fasi di finitura: questo significa uno standard qualitativo inarrivabile con una gestione automatizzata o controlli a campione.

*Each piece is checked during the finishing phases which means an unattainable quality standard with automated management or sample checks.*



# CORPORATE IDENTITY

Salice Paolo fornisce alla propria rete di vendita tutto il supporto necessario a valorizzare il prodotto.

I display standard sono personalizzabili in base alla campionatura scelta e sono disponibili in versione free standing, double face e a parete.

Il packaging assicura la migliore protezione del prodotto ed è completo di tutto il materiale e le informazioni per il montaggio, cura e manutenzione, oltre ai certificati Salice Paolo a garanzia delle finiture a bagno Oro / Argento e ai prodotti con parti in vetro e cristallo.

*Salice Paolo provides its sales network with all the support necessary to enhance the product.*

*The standard displays can be customised according to the chosen sample size and are available in free-standing, double face, and wall versions.*

*The packaging ensures the best product protection which has all the information on assembly, care, and maintenance.*

*It includes Salice Paolo certificates, which guarantee the Gold / Silver plated finishes and products with glass and crystal parts.*



Espositore Timeless a parete  
*Wall-mounted Timeless display*



Cartella finiture Classico e Timeless  
*Classic and Timeless finishing chart*



Packaging Classico e Timeless  
*Classic and Timeless packaging*

SPACE PAOLO

DETAILS



DETTAGLI PER  
L'ARCHITETTURA

LA LINEA PIÙ PURA  
DELLA LINEA  
ELEGANZA  
E SEMPLICITÀ

space & interiors

DIAMANTE





## FINITURE SPECIALI / SPECIAL FINISHES

La gamma Timeless è proposta in sette finiture tra lucide, satinare e antiche, per coprire il più ampio range estetico. Il Bronzo graffiato viene introdotto appositamente per questo catalogo, oltre a due novità assolute per il settore: Oro Champagne, nelle varianti lucido e satinato.

*The Timeless range is offered in seven different finishes including polished, satin and antique effects, to cover the broader aesthetic range. The Scratched bronze is introduced specifically for this catalogue, as well as two new finishes for our market: Champagne gold plated, in polished and satin variants.*



Tutti i trattamenti a bagno Oro (tutti a 24 Carati) e a bagno Argento sono processi certificati da Salice Paolo.

*Gold plated (all 24k) and silver plated treatments are all procedures certified by Salice Paolo.*

ORO CHAMPAGNE LUCIDO  
POLISHED CHAMPAGNE GOLD PLATED



CERTIFIED  
24K  
Ag  
FINISHES

OCL

ORO CHAMPAGNE SATINATO  
SATIN CHAMPAGNE GOLD PLATED



CERTIFIED  
24K  
Ag  
FINISHES

OCS



PARADISE  
WINE & SPIRITS  
ESTABLISHED 1988



YORK  
Itamar Harari  
Finitura / Finish: CR







# INDICE/INDEX

## Maniglie

### *Door handles*

BORBONE	40
BORROMEIO	34
CASSIA	68
CELSIA	110
DECO	48
DIAMANTE	100
FRESIA	58
MEDINA	88
PITTI	76
SFORZA	82
SVEVA	94
TUDOR	18
YORK	26

## Maniglioni

### *Pull handles*

ARNICA	122
ASCOT	118
BORBONE	44
BORROMEIO	38
CASATI	116
CIPRIANI	120
DECO	53
DIAMANTE	106
FRESIA	65
TUDOR	22
VICTORIA	119
YORK	31

## Pomoli

### *Door knobs*

ARUM	128
ASTER	126
BORBONE	43
COSMOS	124
DECO	52
DIAMANTE	105
SVEVA	98
TUDOR	21
YORK	30

## Maniglie per mobili

### *Handles for furniture*

ARIANNA	130
ARUM	129
ASTER	127
BORBONE	45
BORROMEIO	39
DECO	56
DIAMANTE	108
FRESIA	64
PITTI	80
TUDOR	24
YORK	32

## Accessori

### *Accessories*

ARES	135
BORBONE	45
BORROMEIO	39
DECO	57
DORIA	133
CALVI	134
FOSTER	134
KINGSTONE	134
POLO	134
TUDOR	25

**Codici****Codes**

425A	131	2704	43	3251	70
425B	131	2706	52	3251S	61, 71
425C	131	2800	24	3252	72
445BISA	108	2801	24	3253BIS	72
445BISB	108	2802A	24	3255	59
445BISC	108	2802B	24	3256	60
445BISD	108	2804A	32	3257	62
460A	129	2804B	32	3258BIS	62
460B	129	2805A	39	3335	49
461A	127	2805B	39	3336	50
461B	127	2808A	45	3336S	51
1104	135	2808B	45	3337	52
2000	19	2810A	56	3338	52
2001	20	2810B	56	4205	89
2002	21	2811A	56	4206	90
2003	21	2811B	56	4206S	91
2005	27	2812A	64	4207	92
2006	28	2812B	64	4208	92
2007	30	2813A	64	4326A	118
2008	30	2813B	64	4326B	118
2010	35	2814	116	4473A	123
2011	36	2815	121	4473B	123
2012	37	2816A	80	4480	101
2013	37	2816B	80	4481	102
2015	77	2817A	80	4482	104
2016	78	2817B	80	4483BIS	104
2017	79	2900	25	4484	106
2018	79	2901	25	4485A	105
2020	41	2902S	132	4485B	105
2021	42	2903	39	4485C	105
2022	43	2904	39	4485D	105
2023	43	2906	45	4817	127
2025	95	2907	57	4817BIS	129
2026	96	2908	57	4840	111
2027	98	2911	134	4841	112
2028	97	2912	134	4842	113
2029	98	2915S	133	4843BIS	113
2600	22	2915SCF	133	4889A	125
2601	22	2915SWC	133	4889B	125
2602A	31	3010	83	4909S	29
2602B	31	3011	84	4910S	103
2603	38	3011S	85	5200	134
2605	44	3012	86	5201	134
2607	53	3013	86		
2608	65	3033A	119		
2700	21	3033B	119		
2701	30	3250	69		

# TUDOR

Studio Salice Paolo

Finitura / Finish: OL



# TUDOR



## 2000

| 50 |

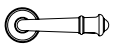

| 50 |

| 50 |

73



| 145 |



# TUDOR



**2001**

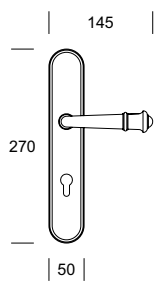



# TUDOR



**2003**

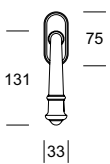

**2002**

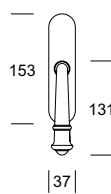

**2700**

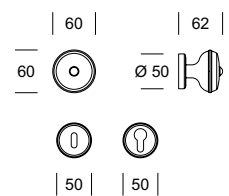



# TUDOR



2601

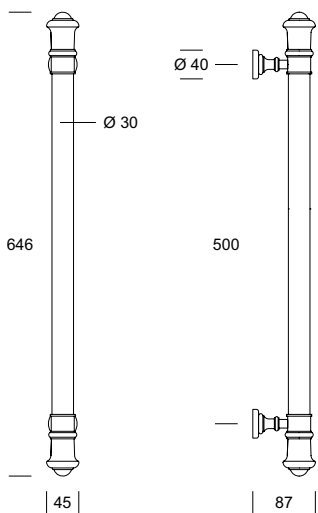

2600

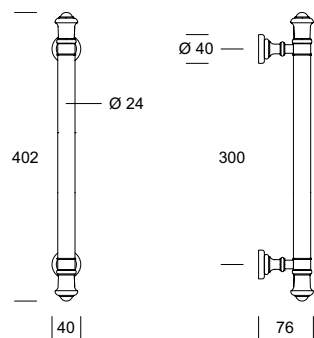



TUDOR  
Finitura / Finish: CR





# TUDOR



Pomolini per mobile  
*Knobs for furniture*

Maniglie per mobile  
*Handles for furniture*



**2800**

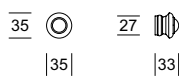

**2801**

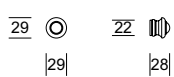

**2802A**

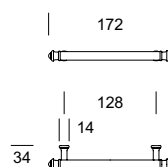

**2802B**

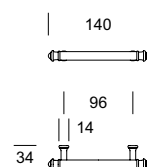

## TUDOR

**2900** 34 41

| 34 |

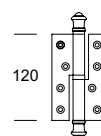
**2901**

120

| 75 |

# YORK

Itamar Harari



Finitura / Finish: CR



# YORK



**2005**



| 50 |

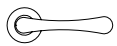

| 50 |

| 50 |

69



| 147 |



# YORK



2006

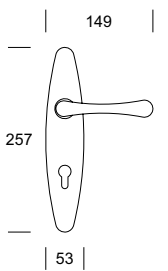

| 53 |



# YORK



**4909S**

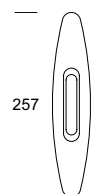

| 53 |



# YORK



**2008**

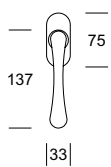

**2007**

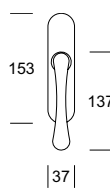

**2701**

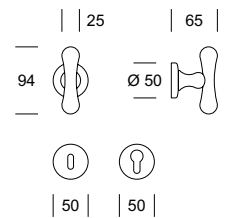



# YORK



**2602A**

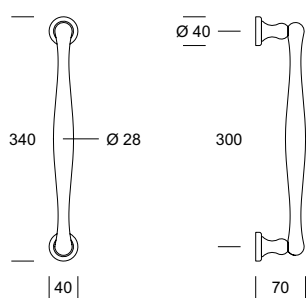

**2602B**

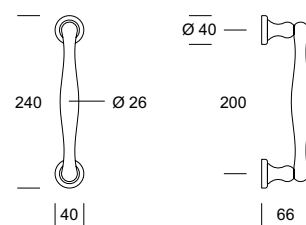





# YORK

Maniglie per mobile  
*Handles for furniture*



**2804A**

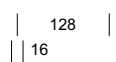
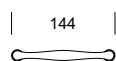

32

**2804B**



32



# BORRAMEO

Studio Salice Paolo



Finitura / *Finish*: OCS



# BORRAMEO



**2010** 

| 50 |

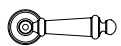

| 50 |

| 50 |

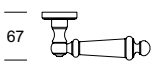

67

| 151 |





# BORRAMEO



2011

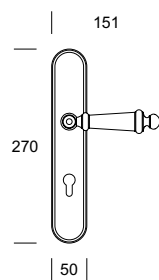



# BORRAMEO



**2013**

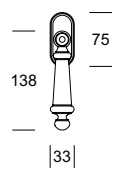

**2012**

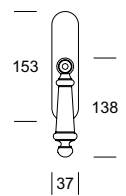



# BORROMEO



2603

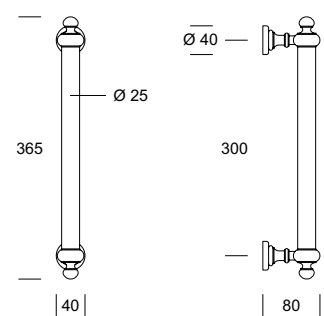

# BORRAMEO



Pomolini per mobile  
*Knobs for furniture*



**2805A**

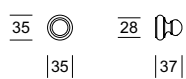

**2805B**

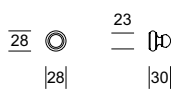

**2903**



**2904**

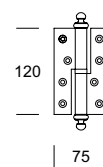



# BORBONE

Studio Salice Paolo



Finitura / Finish: OL



# BORBONE



**2020** 

| 50 |

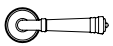

| 50 |

| 50 |

65

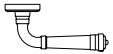

| 144 |





# BORBONE



2021

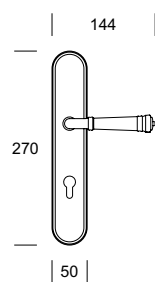



# BORBONE



**2023**

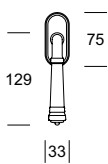

**2022**

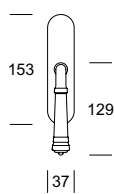

**2704**

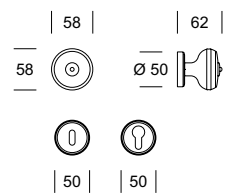



# BORBONE

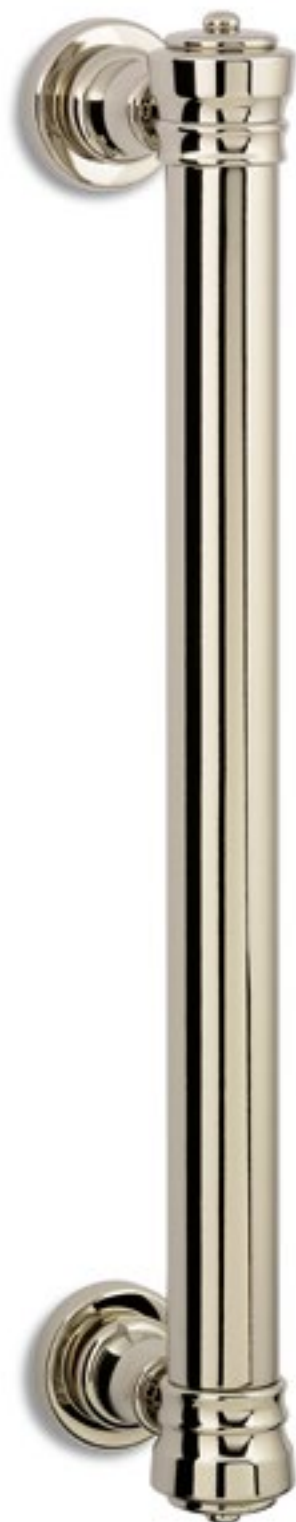

2605

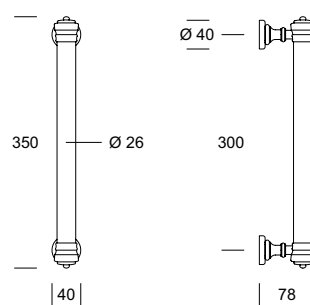

# BORBONE



Pomolini per mobile  
*Knobs for furniture*



**2808A**

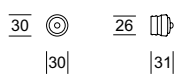

**2808B**

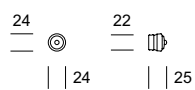

**2906**

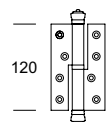

| 75 |

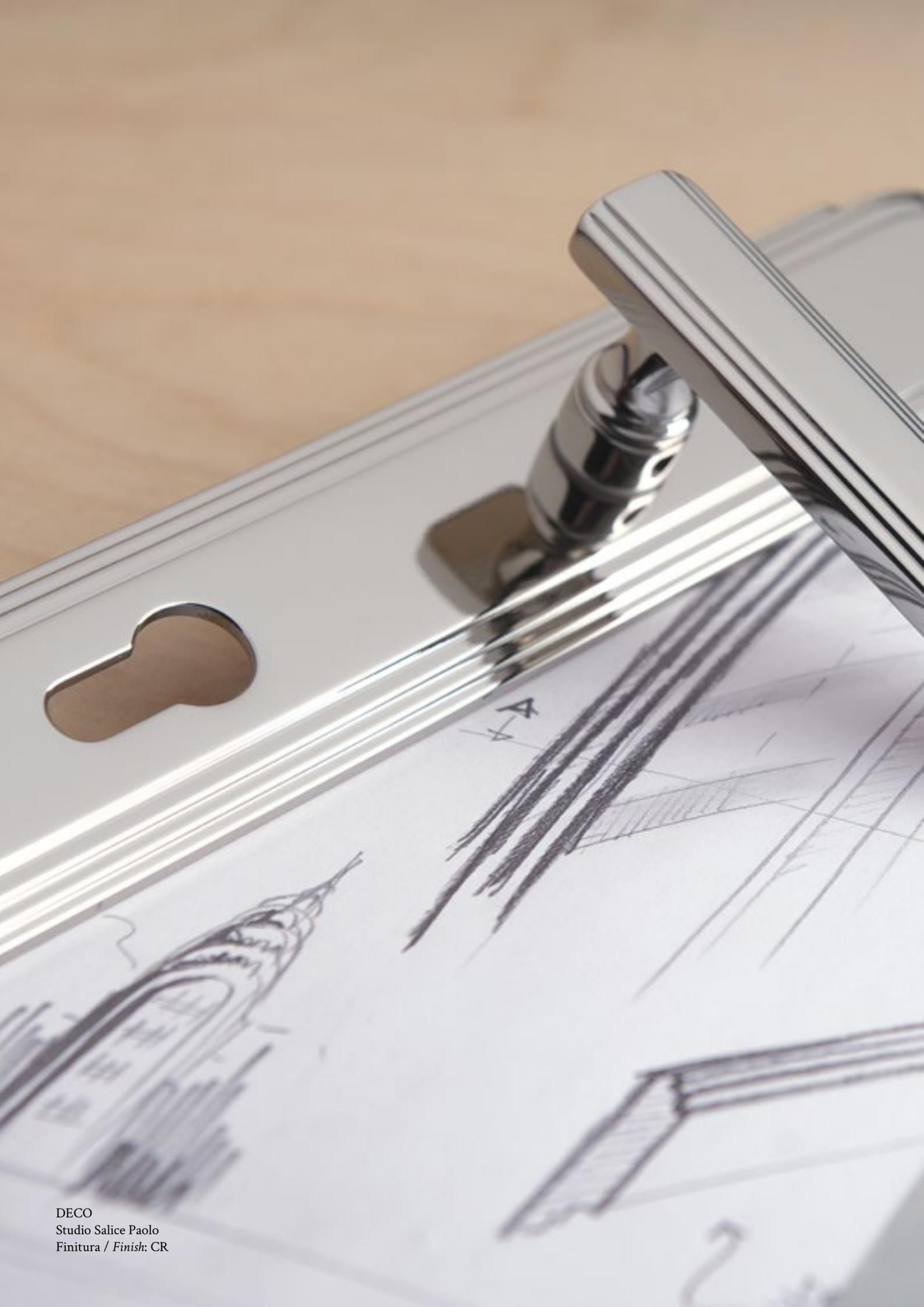

DECO  
Studio Salice Paolo  
Finitura / Finish: CR





# DECO

Studio Salice Paolo



Finitura / Finish: NL



# DECO



**3335**



| 42 |



58

| 42 |

| 42 |

50



| 122 |





# DECO



**3336**

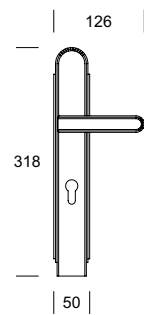



# DECO



**3336S**

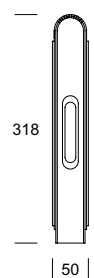

318

| 50 |



# DECO



**3338**

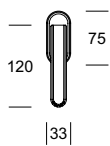

**3337**

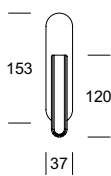

**2706**

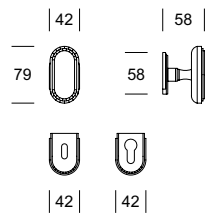



# DECO



**2607**

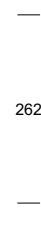

| 42 |

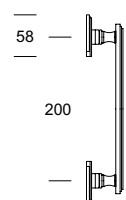

| 51 |



DECO  
Maniglie per mobili / *Handles for furniture*  
Finitura / *Finish: OCS*







# DECO



Pomolini per mobile  
*Knobs for furniture*

Maniglie per mobile  
*Handles for furniture*



**2810A**

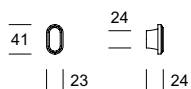

**2810B**

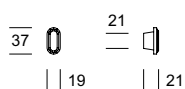

**2811A**

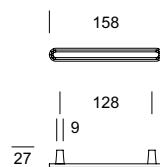

**2811B**

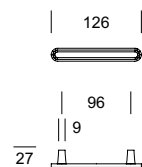



# DECO



**2907**

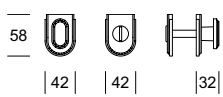

**2908**



# FRESIA

Riccardo Arbizzoni



Finitura / Finish: OCS



# FRESIA



**3255**



| 50 |



| 50 |

| 50 |

—  
68



| 125 |



# FRESIA



**3256**

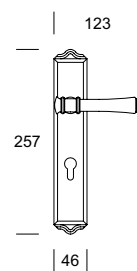

| 46 |



# FRESIA



**3251S**

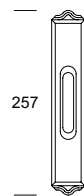

| 46 |



# FRESIA



**3258BIS**

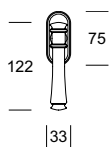

**3257**

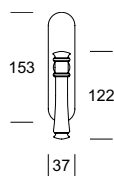



FRESIA  
Cremonese / Window handle  
Finitura / Finish: OL





# FRESIA



Pomolini per mobile  
*Knobs for furniture*

Maniglie per mobile  
*Handles for furniture*



**2812A**

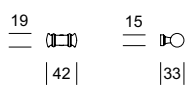

**2812B**

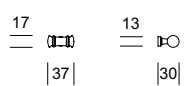

**2813A**

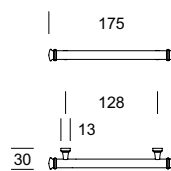

**2813B**

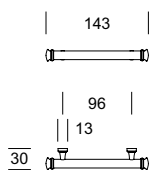



# FRESIA



2608

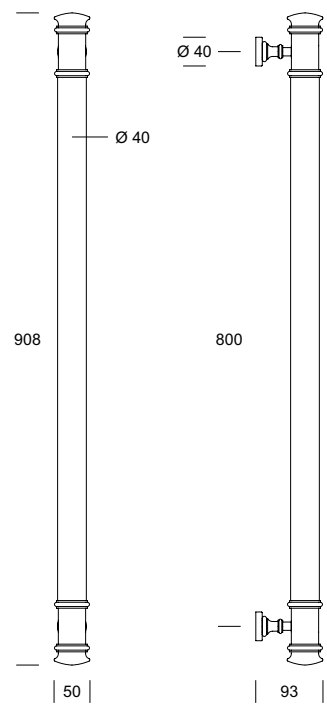



FRESIA  
Maniglione / *Pull handle*  
Finitura / *Finish: OCL*



# CASSIA

Riccardo Arbizzoni





# CASSIA



**3250**



| 50 |



| 50 |

| 50 |

65



| 123 |



# CASSIA



3251

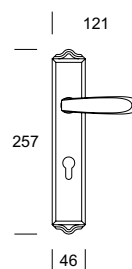

| 46 |



# CASSIA



**3251S**

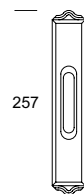

| 46 |







# CASSIA



**3253BIS**

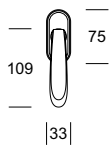

**3252**

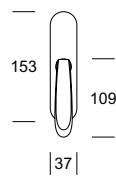





CASSIA  
Maniglia da incasso / *Flush handle*  
Finitura / *Finish*: BG



# PITTI

Studio Salice Paolo





# PITTI



## 2015

| 50 |



| 50 |

| 50 |

62

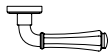

| 140 |



# PITTI



2016

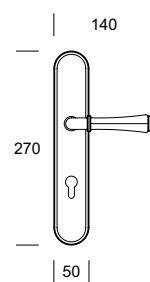



# PITTI



**2018**

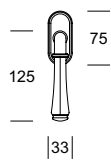

**2017**

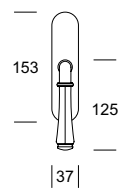





# PITTI



Pomolini per mobile  
*Knobs for furniture*

Maniglie per mobile  
*Handles for furniture*



**2817A**

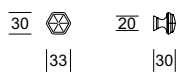

**2817B**

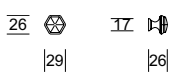

**2816A**

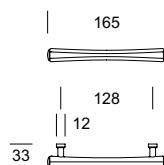

**2816B**

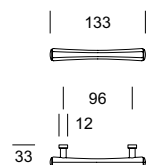



PITTI  
Pomolino per mobili / *Knob for furniture*  
Finitura / *Finish*: OL

# SFORZA

Studio Salice Paolo



Finitura / Finish: OL



# SFORZA



**3010** 

| 50 |

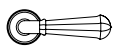

| 50 |

| 50 |

69

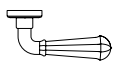

| 145 |



# SFORZA



**3011**

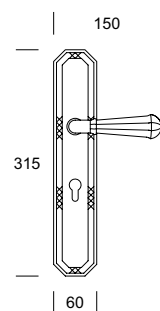



# SFORZA



**3011S**

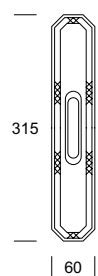



# SFORZA



**3013**

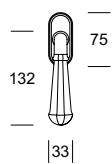

**3012**

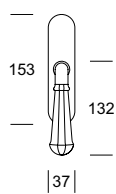





# MEDINA

Studio Salice Paolo





# MEDINA



4205



| 50 |



| 50 |

| 50 |

60



| 140 |



# MEDINA



**4206**

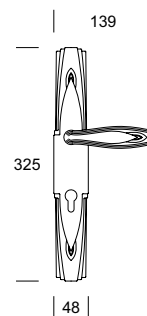



# MEDINA



**4206S**

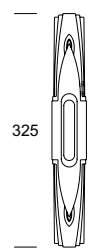



# MEDINA



**4208**

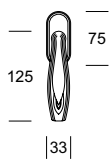

**4207**

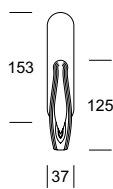



# SVEVA

Studio Salice Paolo





# SVEVA



2025



| 50 |



| 50 |

| 50 |

78



| 129 |







# SVEVA



2026

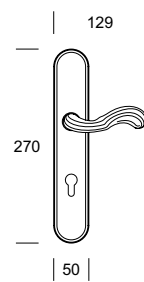



# SVEVA



**2028**

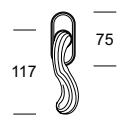

|33|



# SVEVA



**2029**

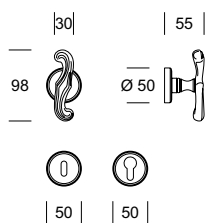

**2027**

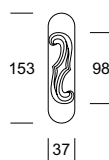



SVEVA  
Pomolo / door knob  
Finitura / Finish: NL

# DIAMANTE

Studio Salice Paolo



Finitura / Finish: CR



# DIAMANTE



4480



| 50 |



| 50 |

| 50 |

70

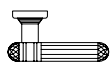

| 140 |



# DIAMANTE



4481

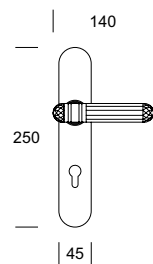



# DIAMANTE



**4910S**

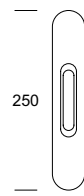

250

| 45 |





# DIAMANTE



**4483BIS** 

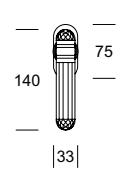

**4482** 

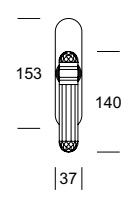

# DIAMANTE

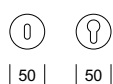
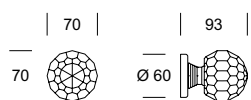
**4485A**

| 50 | | 50 |

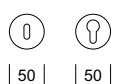
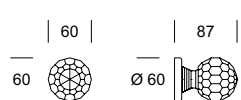
**4485B**

| 50 | | 50 |

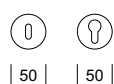
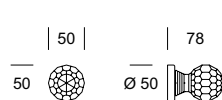
**4485C**

| 50 | | 50 |

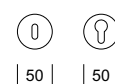
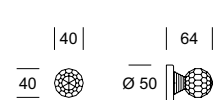
**4485D**

| 50 | | 50 |



# DIAMANTE



4484

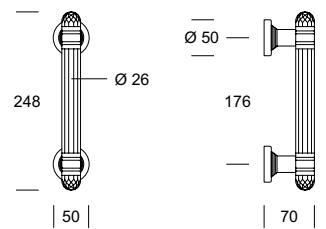



430

DIAMANTE  
Maniglione / Pull handle  
Finitura / Finish: Custom



# DIAMANTE

Pomolini per mobile  
*Knobs for furniture*



**445BISA**

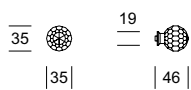

**445BISB**

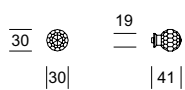

**445BISC**

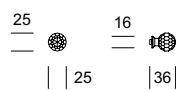

**445BISD**

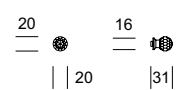



DIAMANTE  
Pomolino per mobili / *knob for furniture*  
Finitura / *Finish*: CR

# CELSIA

Riccardo Arbizzoni



Finitura / Finish: BG



# CELSIA



**4840**



| 50 |



| 50 |

| 50 |



60

| 140 |





# CELSIA



**4841**

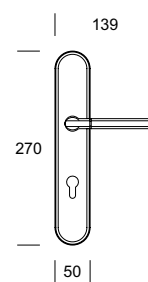



# CELSIA



**4843BIS**

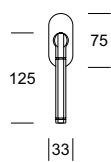

**4842**

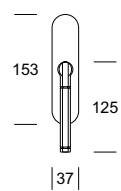



CASATI  
Maniglione / *Pull handle*  
Finitura / *Finish*: ETR





# CASATI



2814 

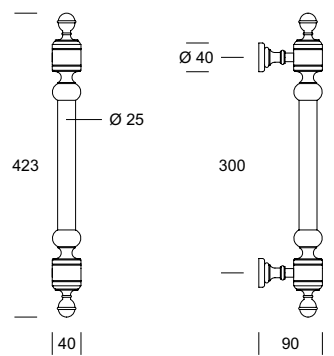



ASCOT  
Maniglione / Pull handle  
Finitura / Finish: OL



# ASCOT



**4326A**

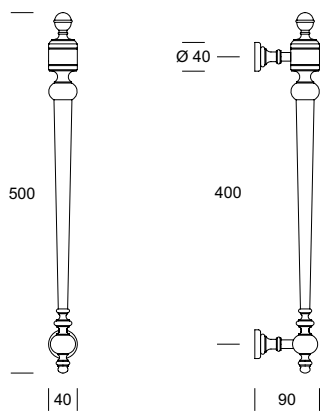

**4326B**

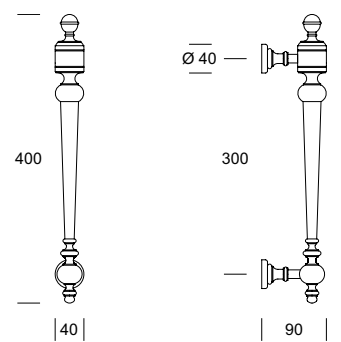

# VICTORIA

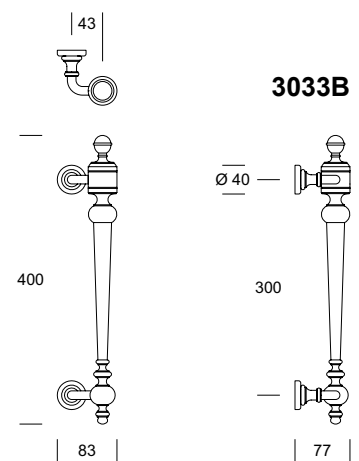
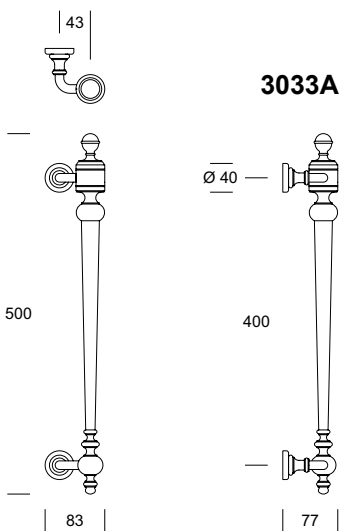



# CIPRIANI

Studio Salice Paolo





2815

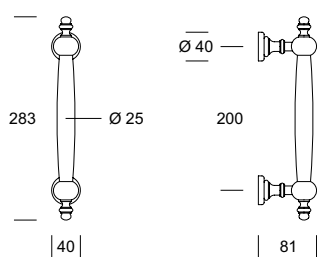

# ARNICA

Studio Salice Paolo



Finitura / Finish: OCS

## ARNICA



4473A

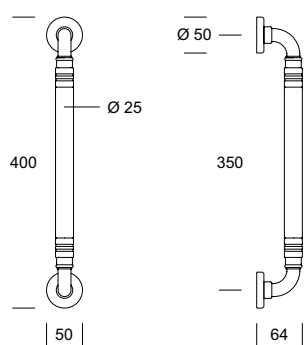

4473B

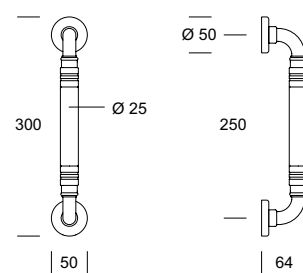

# COSMOS

Studio Salice Paolo

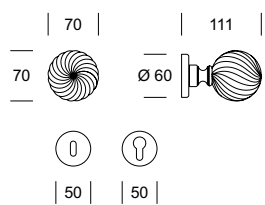
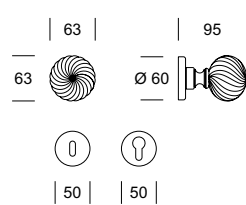

## COSMOS

**4889A****4889B**

# ASTER

Studio Salice Paolo



# ASTER



Pomolini per mobile  
*Knobs for furniture*

**4817**

| 70 | | 98 |

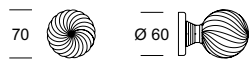

| 50 | | 50 |

**461A**

30		18	
30		42	

**461B**

25		18	
25		35	



# ARUM

Studio Salice Paolo



Finitura / Finish: ETR

# ARUM



Pomolini per mobile  
*Knobs for furniture*



**4817BIS** 

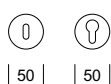

**460A** 

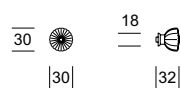

**460B** 

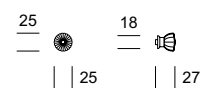

# ARIANNA

Studio Salice Paolo



Finitura / Finish: OL

# ARIANNA

Pomolini per mobile  
*Knobs for furniture*



**425A**

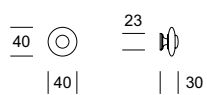

**425B**

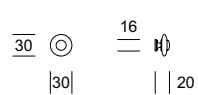

**425C**

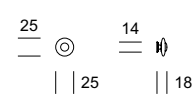



2902S

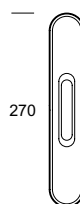

| 50 |

# DORIA

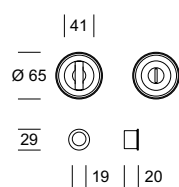
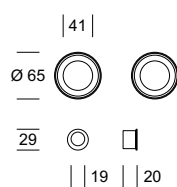
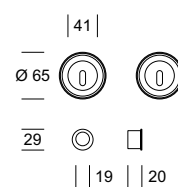
**2915SWC****2915S****2915SCF**



# NOTTOLINI / DOOR LATCH



**KINGSTONE**

**5200**

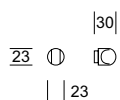

**FOSTER**

**2911**

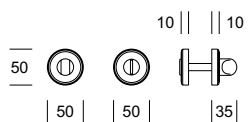

**CALVI**

**2912**

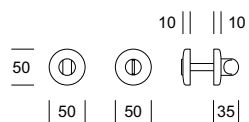

**POLO**

**5201**

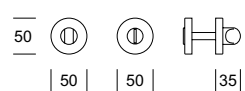



# ARES



**1104**

| 83 |



| 51 |





## FINITURE / FINISHES



NL

Nichel lucido  
Polished nichel  
Nichel poli  
Nichel brillo  
Блестящая никель



OL

Ottone lucido  
Polished brass  
Laiton poli  
Laton brillo  
Блестящая латунь



BG

Bronzo graffiato  
Scratched bronze  
Bronze rayé  
Brunito rayado  
бронза поцарапан



ETR

Etrusco  
Этрусско Этрусский стиль



CERTIFIED  
24K  
Ag  
FINISHES

OCL

Oro champagne lucido  
Polished champagne gold plated  
Champagne doré poli  
Dorado champagne brillo  
золотой блеск шампанского



CERTIFIED  
24K  
Ag  
FINISHES

OCS

Oro champagne satinato  
Satin champagne gold plated  
Champagne doré satiné  
Dorado champagne satinado  
Шампанского позолотой



WARRANTY  
10  
YEARS

CR

Cromo  
Chrome  
Chromé  
Cromato  
Хром



## INFORMAZIONI TECNICHE / TECHNICAL INFORMATION

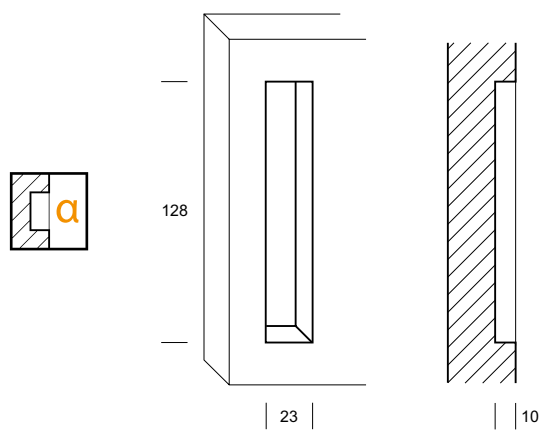

Fresatura maniglia incasso  
 Milling of fitted handle  
 Fraisage poignée encastrée  
 Fresado del tirador empotrado  
 Врезка ручек

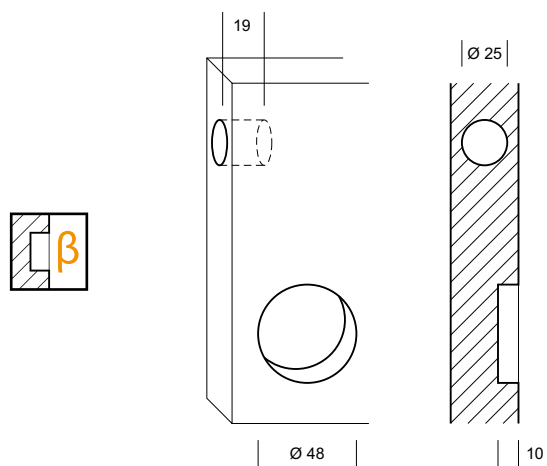

Fresatura maniglia incasso  
 Milling of fitted handle  
 Fraisage poignée encastrée  
 Fresado del tirador empotrado  
 Врезка ручек

## INFORMAZIONI TECNICHE / TECHNICAL INFORMATION

GERMAN KIT DISPONIBILE SU RICHIESTA PER LA GAMMA TIMELESS \*  
 GERMAN KIT AVAILABLE ON REQUEST FOR THE TIMELESS RANGE \*

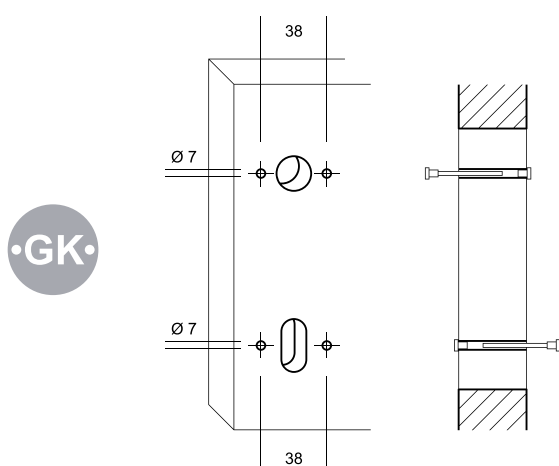

Fori passanti per sottorosette  
 Through holes for roses metal bosses  
 Trous passage pour bossette de rosace  
 Agujeros a través por placa en metal para boqueta  
 Сквозные отверстия для крепления подрозетников

Il German Kit GK è la nuova guarnitura Salice Paolo per tutte le situazioni in cui non è possibile usare il sistema standard di sottorosette, ad esempio con spessori ridotti o scarsa tenuta del legno. Due tiranti filettati fissano saldamente ogni coppia di sottorosette alla porta, attraverso due fori passanti con interasse 38 mm.

Il sistema è perfettamente compatibile con le rosette tradizionali ed è disponibile nelle versioni per bocchette Patent e Yale.

*The GK German Kit is the new Salice Paolo fixing kit for all those circumstances when the standard subrose fixing system is not an option, i.e. when door thicknesses are very thin or in case of poorness of the timber.*

*Two threaded rods firmly secure both subroses to the door, through 2 holes with a center distance of 38 mm.*

*The system is fully compatible with traditional roses and is available in versions for both Patent and Yale escutcheons.*

\*Eccetto DECO / Except DECO

Il presente catalogo rappresenta i prodotti Salice Paolo nel modo più fedele possibile, eventuali differenze di dettaglio e nelle finiture sono da considerarsi peculiari della lavorazione semiartigianale, o risultato di un costante miglioramento.

*This catalogue represents the Salice Paolo products as faithfully as possible, any differences in detail are to be considered peculiar to semi-artisan process, or result of constant improvement.*

Creative direction: Davide Diliberto

Si ringrazia / *Thanks to:*

Laurameroni Design Collection - [www.laurameroni.com](http://www.laurameroni.com)  
14 - 15, 26, 68, 82, 88, 100, 114 - 115, 122, 126

Arnaboldi Interiors - [www.arnaboldiinteriors.it](http://www.arnaboldiinteriors.it)  
18, 34, 128

Bragotto e Urbinati - [www.bragottoeurbinati.it](http://www.bragottoeurbinati.it)  
74 - 75, 76, 94, 99, 110

Hotel Vista Palazzo, Lago di Como - [www.vistalagodicomo.com](http://www.vistalagodicomo.com)  
63, 107

Martini Interiors - [www.martini-interiors.com](http://www.martini-interiors.com)  
23, 54 - 55

Cappelletti - [www.cappellettisrl.com](http://www.cappellettisrl.com)  
117

Printed in Italy, 05/2021

  
Salice Paolo

**SALICE PAOLO srl**  
**Via Domea, 45**  
**22063 Cantù (CO) Italy**  
**T +39 031 714520**  
**[info@salicepaolo.it](mailto:info@salicepaolo.it)**  
**[www.salicepaolo.it](http://www.salicepaolo.it)**