

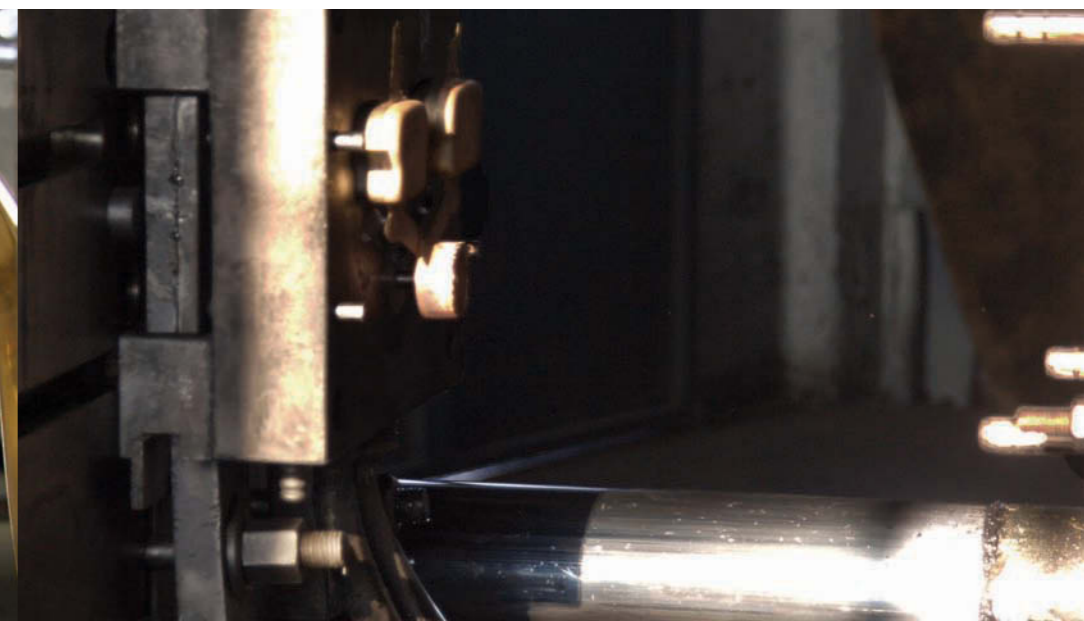

Salice Paolo

2014

L'AZIENDA OUR COMPANY

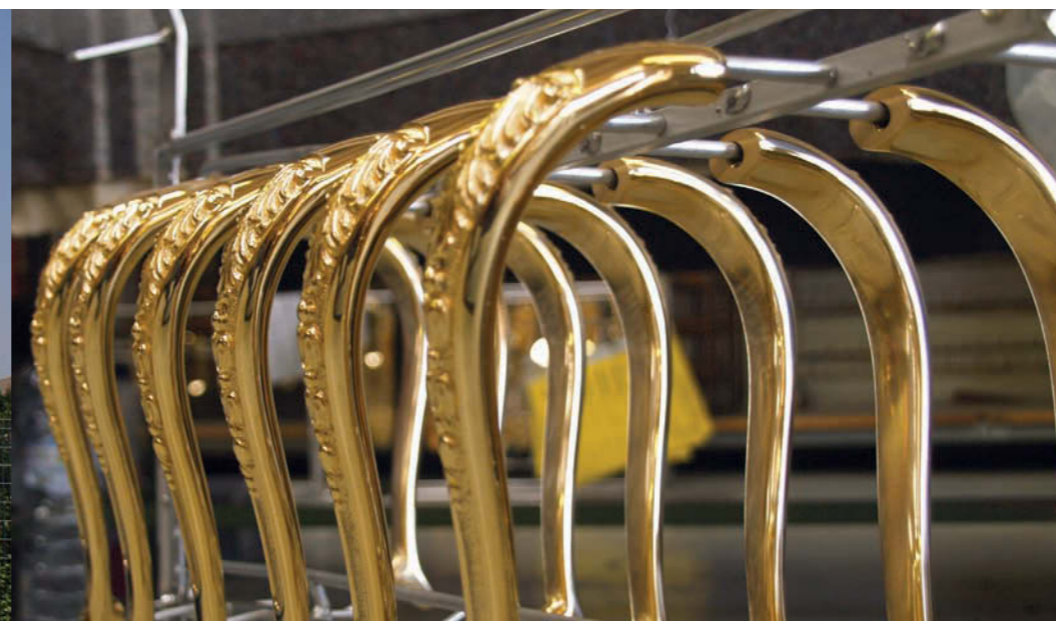

Chi siamo

Paolo Salice crea la sua linea di maniglie classiche a cavallo degli anni 40-50, sfruttando il know how acquisito nella lavorazione dell'ottone.

Tecnica, cultura e competenze artigianali si fondono in una gamma completa per stili e finiture, posizionata nella fascia alta del mercato.

Gli ultimi decenni vedono l'ingresso nel settore moderno, dove la competizione ancor più dura, non lascia alternativa alla ricerca della massima qualità e di un design originale, sempre in equilibrio fra sobrietà e personalità.

Lo stabilimento di Cantù vanta sistemi di depurazione delle acque di processo e per l'aria, conformi alle più recenti normative in materia. Ed ancora, l'installazione di un sistema di grassaggio ad acqua che elimina totalmente l'uso di solventi, persino quelli oggi dichiarati "non dannosi".

Giunta alla sua terza generazione, la famiglia Salice sta guidando il marchio verso importanti cambiamenti, nel rispetto della sua non comune tradizione e in difesa di una produzione genuinamente Made in Italy.

About us

Paolo Salice creates its own line of classic handles at the turn of 40ties and 50ties, taking advantage of the know-how acquired in the machining of brass.

Technology, culture and craft skills come together in a full range of styles and finishes, positioned at the high end of the market. The last decades saw its entry into the modern ground, where competition is even tougher, and leaves no alternative to the research of the highest quality and original designs, always in balance between sobriety and personality.

The plant in Cantù is equipped with a special purification system for processed water and for the air, in compliance with the latest regulations. And yet, the installation of a water degreasing system that eliminates the use of solvents, even those declared today "not harmful".

Now in its third generation, the Salice family is driving the brand to major changes, in accordance with its tradition in defense of a genuinely Made in Italy production.

A propos de nous

Paolo Salice crée sa ligne de poignées classiques dans les années 40/50 en exploitant le savoir-faire acquis pendant l'usinage du laiton.

Technique, culture et compétences artisanales s'unissent dans une gamme complète en termes de styles et de finitions, positionnée sur le marché haut de gamme.

Ces dernières décennies marquent l'entrée dans le secteur moderne, où la concurrence, encore plus rude, ne laisse pas d'alternative à la recherche de la qualité la plus élevée et d'un design original, tout en maintenant l'équilibre entre la sobriété et la personnalité.

L'établissement de Cantù dispose de systèmes d'épuration des eaux de traitement et pour l'air, conformes aux normes les plus récentes en la matière. Et encore, l'installation d'un système de lubrification à l'eau, qui élimine totalement l'utilisation de solvants, même ceux déclarés aujourd'hui "non nocifs".

Il revient maintenant à la troisième génération de la famille Salice de mener la marque vers des changements considérables, tout en respectant sa tradition et en défendant une production authentique Made in Italy.

Sobre nosotros

"Paolo Salice crea su propia línea de tiradores clásicos, durante los años 40-50, aprovechando el know how adquirido con el mecanizado del latón.

Técnica, cultura y habilidades artesanas se funden en una gama completa de estilos y acabados, colocándose en el segmento superior del mercado.

Las últimas décadas han presenciado la entrada en el sector moderno, donde la competencia es aún más difícil, pues no deja ninguna alternativa a la búsqueda de la máxima calidad y a un diseño original, siempre en equilibrio entre la sobriedad y la personalidad.

La fábrica de Cantù cuenta con sistemas de depuración de las aguas de proceso y del aire, que cumplen con las normas más recientes. Además, también posee un sistema de lubricación por agua que elimina totalmente el uso de solventes, incluso de aquellos que actualmente son declarados como "no perjudiciales". Actualmente, en su tercera generación, la familia Salice está impulsando la marca hacia cambios importantes, de acuerdo con la tradición, y en defensa de una producción genuinamente Made in Italy."

О НАС

Паоло Саличе создал свою линию классических ручек на рубеже 40 и 50-х годов, используя ноу-хау, приобретенное в сфере обработки латуни.

Ремесленная техника, культура и компетентность позволили создать полный ассортимент стилей и отделок, позиционирующийся в верхнем сегменте рынка.

В последние несколько десятилетий компания начала работать также в секторе современного стиля, характеризующемся еще более жесткой конкуренцией, не оставляющей возможности обеспечения максимального качества и оригинального дизайна, все также сохраняя строгость и индивидуальность.

Завод в Канту' оснащен системами очистки промышленных стоков и воздуха, соответствующими самым последним стандартам. Кроме того, установка системы водяного обезжиривания позволит полностью отказаться от использования растворителей, даже тех, которые сегодня считаются «невредными».

Уже третье поколение семьи Саличе ведет бренд к крупным переменам при сохранении традиций и защите полностью итальянского производства.



QUALITÀ QUALITY

Ogni prodotto Salice Paolo è distinto dal marchio **V.I.P (Very Italian Product)** a garanzia di provenienza e qualità. Sull'etichetta di ogni confezione è riportato il codice **Trace Me Code** che consente di verificarne online l'autenticità.

*All Salice Paolo products are characterized by the **V.I.P (Very Italian Product)** brand that guarantees its origin and quality. All the labels stuck on the boxes of Salice Paolo products have the **Trace Me Code**. Thanks to an online tracking system, the customer can verify that the purchased item is genuine.*



Molla di ritorno

Return spring
Ressort de retour
Retorno por resorte
доводчиком



Cristallo

Crystal
Cristal
Cristal
Кристалл



Vetro

Glass
Verre
Vidrio
Стекло



Plexiglass

Plexiglass
Plexiglas
Plexiglás
Плексиглас



GAMMA RANGE

Ogni modello può essere abbinato ad accessori della stessa serie o compatibili.

Salice Paolo può suggerire le combinazioni più collaudate, specialmente nella gamma classica dove la scelta è più articolata.

Each model can be combined with accessories of the same series or well-suited.

Salice Paolo can suggest the most established matching, especially in the classic range where the choice is more challenging.

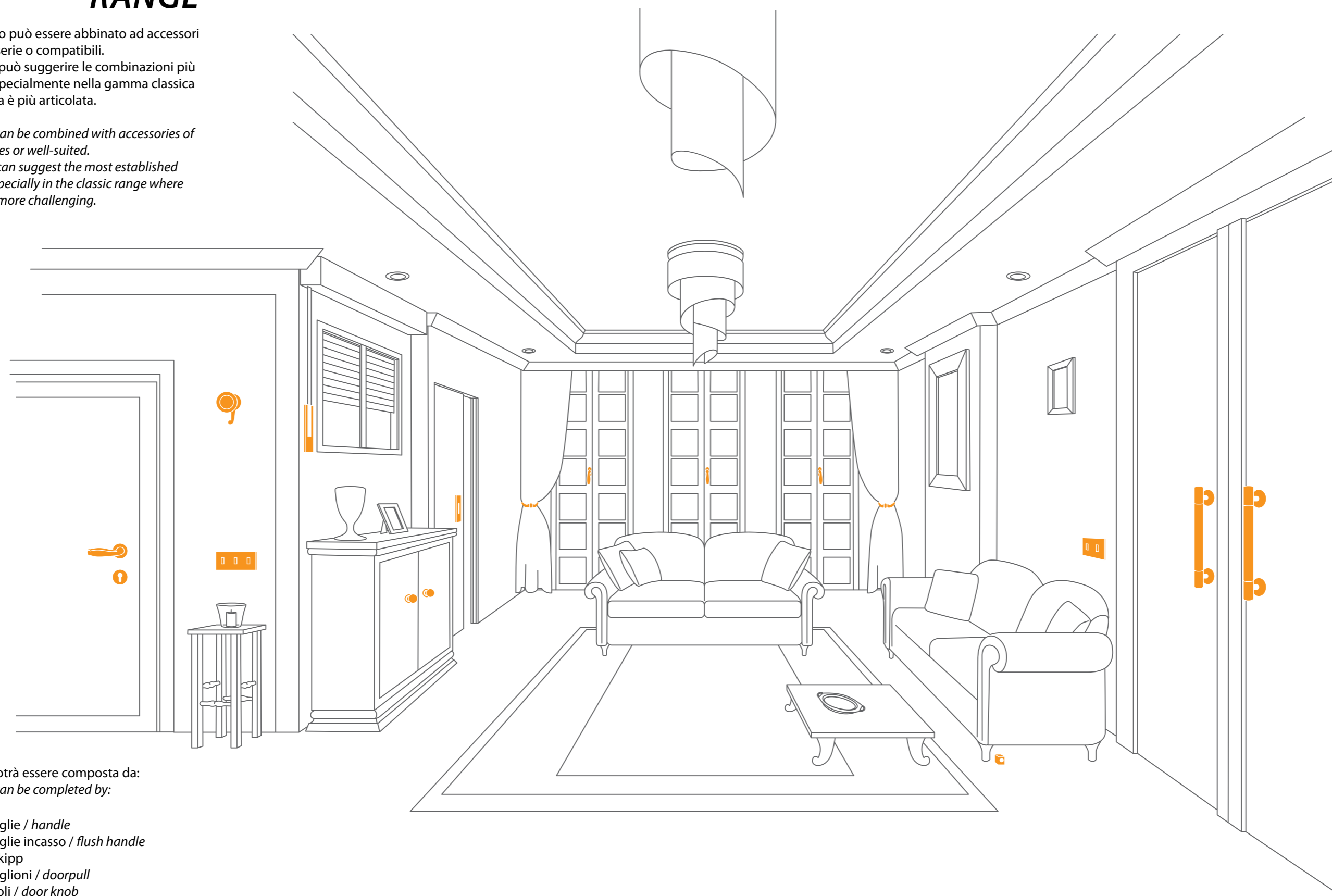

Ogni serie potrà essere composta da:
Each model can be completed by:

-  Maniglie / handle
- Maniglie incasso / flush handle
- Dreykipp
- Maniglioni / doorpull
- Pomoli / door knob
- Coprinterruttori / switch cover plate
- Placche copriavvolgibili / window cover plate
- Portabiti / hook
- Fermatende / knob for curtain
- Maniglie e decorazioni per mobili / handles and decoration for furniture



CLASSICO / CLASSIC

Maniglie Handles

ATENE	144
AVIGNONE	142
BAKU	177
BEIRUT	218
BERLINO	242
BORDEAUX	143
BRUGES	194
CADICE	216
CAPUA	178
CASSIA	184
DAKAR	170
DAMASCO	206
DECO	188
DELHI	222
DOHA	172
FRESIA	182
GINEVRA	158
HANNOVER	240
IL CAIRO	220
JAKARTA	232
KIEV	161
KING	165
LILLE	179
LIMOGES cremonese	215
LISBONA	197
LUCCA	151
LUXOR	157
MADRID	244
MASQUAT	200
MEDINA	190
MONTPELLIER	156
NANCY	145
NAXOS	175
ORLEANS	210
ORLEANS cremonese	212
PAESTUM	169
POMPEI	226
REIMS	152
RIYADH	224
ROCHEFORT	148
SAMARRA	202
SHANGHAI	230
SHARJAH	146
TODI	162
TOURS	147
URBINO	235
VARSAVIA	238
VERSAILLES	166
VIENNA	208

Maniglioni Doorpull

ALAIS	266
ANKARA	255
ASCOT	248
BOMBAY	252
BOULOGNE	264
BYBLOS	270
CORINTHUS	273
DESSAN	265
GULLIVER	257
ISTAMBUL	254
KARACHI	253
KING	261
LION	259
MADRAS	256
MANILA	278
MATERA	276
MEDA	279
MILSE	267
NEKLA	268
PARIGI	280
PRINCE	263
RHODUS	272
SEOUL	269
SNAKE	251
SPARTA	271
VICTORIA	249

Pomoli Door knob

LE HAVRE	286
LENINGRADO	290
LIONE	284
MOSCA	285
NANTES	289
RENNES	288
SAMARCANDA	287

Entrance set

ALADIN	314
BOSTON	298
DENVER	306
MEMPHIS	294
MIAMI	318
NEW YORK	322
SEATTLE	326

Entrance set Yale

ALADIN Y	339
BOSTON Y	334
DENVER Y	336
MEMPHIS Y	338
MIAMI Y	340
NEW YORK Y	341
SEATTLE Y	342

Accessori, fermatende, portabiti

Accessories, knob for curtain, hook

AGRIGENTO	356
AOSTA	364
ARONA	354
BELLAGIO	358
BRASILIA	349
BRISTOL	365
CANNES	361
CAPRI	353
CARACAS	348
DIONISO	372
FIRENZE	355
GALATEA	368
LA PAZ	352
LEEDS	365
LONDRA	365
MILANO	357
NESEA	373
NIZZA	361
NORCIA	346
PISA	362
PRAGA	363
QUITO	351
SANTIAGO	350
SIENA	362
SOFIA	363
STALINGRADO	347
STRESA	353
TAORMINA	360

Maniglie e decorazioni per mobili

Handles and decorations for furniture

BOTTICELLI	383
CARAVAGGIO	379
GIOTTO	377
LEONARDO	382
MASACCIO	376
MICHELANGELO	380
RAFFAELLO	381
TIZIANO	378

Codici Codes

1	385	90	390	442/A	393	3077/S	160
5	384	91	390	442/B	393	3078/S	161
6	384	92	390	443/A	393	3078/S CF	161
7	384	092/A	392	443/B	393	3078/S WC	161
17	384	092/B	392	444/A	393	3080/B	279
20/A	384	93	390	444/B	393	3081/B	279
20/B	384	94	390	444/C	393	3090	162
22	385	0105/A	379	500/FT	348	3091	162
024/A	392	0105/B	379	500/P	348	3095	165
024/B	392	0105/C	379	501/FT	351	3096	165
024/C	392	0109	392	501/P	351	3099	263
26/C	384	136	367	502/FT	350	3100/3001	166
26/F	384	137	367	502/P	350	3100/3085	166
32	384	0150/A	392	503/FT	349	3104	365
34	384	0150/B	392	503/P	349	3105	365
35	384	0150/C	392	504/FT	352	3110	286
36	384	0152/A	392	504/P	352	3115/3015	143
37/B	385	0152/B	392	1028/A	392	3116/3019	144
37/C	385	300	362	1028/B	392	3117	169
38	385	301	362	1032	392	3118	169
39	385	311/A	369	1100	361	3120	347
40	384	311/B	369	1101	361	3200	294
41	384	311/C	370	1933/A	393	3200/DC	296
43	389	311/D	370	1933/B	393	3200/Y	338
44	389	311/E	371	3001/S	167	3201	296
45	384	311/F	371	3007	353	3202	297
51	385	312	372	3014/S	142	3203	297
52	385	313	372	3016/S	145	3204	297
53	385	320	373	3020	146	3205	298
54	385	416/A	392	3021	146	3205/DC	300
55	386	416/B	392	3026	147	3205/Y	334
56	386	417/A	378	3031	148	3206	300
57	386	417/B	378	3031/S	149	3207	301
58	386	417/C	378	3032	148	3208	301
59	386	420/A	377	3033	249	3209	301
60/A	386	420/B	377	3034	255	3210	302
60/B	386	420/C	377	3035	251	3210/DC	304
61/A	386	423/A	392	3036	252	3210/Y	335
61/B	386	423/B	392	3037	259	3211	304
62	387	429/A	376	3038	261	3212	305
63	387	429/B	376	3039/A	257	3213	305
64	387	429/C	376	3039/B	257	3214	305
65	387	430/A	382	3040	151	3215	306
66	388	430/B	382	3041	151	3215/DC	308
67	387	430/C	382	3045	152	3215/Y	336
68	387	432/A	393	3046	152	3216	308
69	387	432/B	393	3047	153	3217	309
70	388	434/A	383	3047/4340	153	3218	309
71	388	434/B	383	3051	156	3219	309
72	388	434/C	383	3051/S	156	3220	310
73	388	435/A	380	3055	157	3220/DC	312
74	391	435/B	380	3056	157	3220/Y	337
75	391	435/C	380	3060	264	3221	312
76	391	435/D	380	3061	265	3222	313
77	391	435/E	380	3062	266	3223	313
78	389	436/A	381	3063	267	3224	313
79	389	436/B	381	3064	268	3225	314
80	389	436/C	381	3065	269	3225/DC	316
81	389	436/D	381	3066	270	3225/Y	339
82	389	436/E	381	3067	256	3226	316
83	389	438/A	393	3068	272	3227	317
84	389	438/B	393	3069	273	3228	317
85	389	439/A	393	3070	253	3229	317
86	389	439/B	393	3071	271	3230	318
87	389	440/A	393	3075	158	3230/DC	320
88	390	440/B	393	3076	159	3230/Y	340
89	390	440/C	393	3076/S	160	3231	320

CLASSICO / CLASSIC

3232	321	4255	200	4326	248	4800	353
3233	321	4256	200	4327	280		
3234	321	4256/S	201	4328	254		
3235	322	4258	201	4329	346		
3235/DC	324	4258/4255	201	4330	230		
3235/Y	341	4270	202	4331	230		
3236	324	4271	202	4332	231		
3237	325	4273	203	4332/4330	231		
3238	325	4273/4270	203	4335	232		
3239	325	4285	206	4336	232		
3240	326	4286	206	4338	233		
3240/DC	328	4286/S	207	4338/4335	233		
3240/Y	342	4287	207	4340	235		
3241	328	4287/4285	207	4341	235		
3242	329	4290	208	4342	237		
3243	329	4291	208	4342/4340	237		
3244	329	4293	209	4345	238		
3250	185	4293/4290	209	4345/C	239		
3251	184	4295	210	4345/C-P	366		
3253	185	4295/3006A	216	4346	238		
3253/BIS	185	4295/3006B	217	4346/S	239		
3255	183	4295/3085	217	4347	239		
3256	182	4296	210	4347/4345	239		
3257	183	4296/S	211	4350	240		
3258/BIS	183	4297	211	4351	240		
3260	170	4297/4199A	215	4351/S	241		
3261	170	4297/4295	211	4352	241		
3262	171	4297/4299A	212	4352/4350	241		
3262/3085	171	4297/S	211	4390	242		
3265	287	4299/B	212	4391	242		
3266	288	4299/C	212	4391/S	243		
3267	289	4299/D	212	4392	243		
3270	290	4300	218	4392/4390	243		
3300	172	4301	218	4409	365		
3301	173	4301/S	219	4415	244		
3302	172	4302	219	4416	244		
3305	175	4302/4300	219	4416/S	245		
3306	176	4305	220	4417	245		
3307	175	4306	220	4417/4415	245		
3310	177	4307	221	4506	355		
3311	177	4307/4305	221	4507	355		
3315	178	4310	222	4508	355		
3316	178	4311	222	4508/4	355		
3320	179	4311/2	224	4508/5	355		
3321	179	4312	223	4510	354		
3330	194	4312/4310	223	4511	354		
3331	194	4315	226	4512	354		
3331/S	195	4315/3014	142	4515	357		
3335	188	4315/3016	145	4516	357		
3336	188	4315/C	227	4517	357		
3336/S	189	4315/C-P	366	4517/4	357		
4100/A	364	4316	226	4517/5	357		
4100/B	364	4316/S	227	4520	358		
4100/C	364	4317	227	4535	358		
4100/D	364	4317/4315	227	4536	358		
4101	363	4320	285	4537	359		
4102	363	4321/A	284	4538	359		
4199/B	215	4321/B	284	4539	359		
4199/C	215	4321/C	284	4540	360		
4199/D	215	4322	276	4549	360		
4205	190	4322/S	277	4550	360		
4206	190	4323	276	4570	356		
4206/S	191	4323/S	277	4571	356		
4250	197	4324	276	4572	356		
4251	197	4324/S	277	4600	355		
4252	199	4325	278	4601	357		
4252/4250	199	4325/S	278	4602	356		

Epoche e Stili Periods and styles

EPOCA SECOLO XIV		STILE LOUIS XV		STILE REGENCY		STILE FIORENTINO	
IL CAIRO	220	BRUGES	194	MASQUAT	200	KING maniglione	261
QUITO	351	FIRENZE	355			PRINCE	263
		GULLIVER	257	STILE VITTORIANO			
EPOCA TARDO '600		JAKARTA	232	MADRID	244	STILE FLOREALE	
DAMASCO	206	MEMPHIS	294			BAKU	177
		MEMPHIS Y	338	STILE COLONIALE			
EPOCA METÀ '700		MOSCA	285	ASCOT	248	STILE ART DECO	
CAPUA	178	REIMS	152	VICTORIA	249	DECO	188
MANILA	278	SANTIAGO	350			MEDINA	190
PAESTUM	169	SEATTLE	326	STILE INGLESE			
RENNES	288	SEATTLE Y	342	BELLAGIO	358		
		SEOUL	269	CARACAS	348		
		TOURS	147	HANNOVER	240		
		VARSAVIA	238	LEEDS	365		
		4345/C-P	366	MILANO	357		
				SAMARCANDA	287		
				STRESA	353		
EPOCA TARDO '700		STILE LOUIS XVI				STILE IMPERO	
ATENE	144	ARONA	354	AGRIGENTO	356		
BRASILIA	349	BRISTOL	365	AVIGNONE	142		
CORINTHUS	273	CADICE	216	BOSTON	298		
LE HAVRE	286	GALATEA	368	BOSTON Y	334		
LIONE	284	LA PAZ	352	BOULOGNE	264		
NORCIA	346	LILLE	179	DENVER	306		
RHODUS	272	LIMOGES cremonese	215	DENVER Y	336		
SHANGHAI	230	NESEA	373	DESSAN	265		
SPARTA	271	ORLEANS	210	DOHA	172		
		ORLEANS cremonese	212	NANCY	145		
EPOCA FINE '800		PARIGI	280	NAXOS	175		
CASSIA	184	VERSAILLES	166	POMPEI	226		
FRESIA	182	VIENNA	208	TAORMINA	360		
SNAKE	251			URBINO	235		
				4315/C-P	366		
EPOCA METÀ XVII SECOLO		STILE BAROCCO		STILE ROMANICO			
DELHI	222	LISBONA	197	LION	259		
				STILE NEOCLASSICO			
STILE LUIGI FILIPPO-FINE 1700		STILE BAROCCO PIEMONTESE		BEIRUT	218		
GINEVRA	158	SAMARRA	202	BORDEAUX	143		
KING	165			BYBLOS	270		
MEDA	279	STILE CHIPPENDALE		CAPRI	353		
MIAMI	318	ANKARA	255	MATERA	276		
MIAMI Y	340	BOMBAY	252			STILE ARABESCO	
MILSE	267	ISTANBUL	254	ALADIN	314		
ROCHEFORT	148	KARACHI	253	ALADIN Y	339		
TODI	162	MADRAS	256	ALAIS	266		
		NEKLA	268	RIYADH	224		
STILE '700 TEDESCO		MONTPELLIER	156	SHARJAH	146		
BERLINO	242	NANTES	289			STILE INFLUSSO ORIENTALE	
		NEW YORK	322	LUXOR	157		
		NEW YORK Y	341				
STILE '700 SPAGNOLO							
LUCCA	151	STILE NEOCLASSICO					
LENINGRADO	290	BEIRUT	218				
STALINGRADO	347	BORDEAUX	143				
		BYBLOS	270				
STILE RIESENER		CAPRI	353				
DAKAR	170	MATERA	276				





CLASSICO CLASSIC

La gamma classica Salice Paolo copre tutti i principali stili ed epoche, con disegni originali fatti realizzare da artigiani cresciuti nella prestigiosa Scuola di Arti e Mestieri di Cantù. Le finiture disponibili, la possibilità di personalizzazione e il gran numero di accessori consentono di arredare completamente grandi abitazioni private, ville e resort di prestigio. Pur guardando al passato, la gamma classica Salice Paolo si arricchisce continuamente di nuove finiture, modelli, aggiornamenti, dotazioni tecniche, versioni per tutti i tipi di serrature da interno ed esterno.

The classic Salice Paolo range covers all the main periods and styles, with its original designs made by the artisans grown in the prestigious School of Arts and Crafts in Cantù. The available finishings, the possibilities for customization and the large number of accessories allow you to fully furnish large private homes, as well as villas and luxury resorts. While looking at the past, the classic range of Salice Paolo is continuously enriched by new finishes, patterns, updates, technical equipment, and varieties for all types of locks from inside and outside.



AVIGNONE

Stile: Impero



Stile: Neoclassico



BORDEAUX



3115/3015

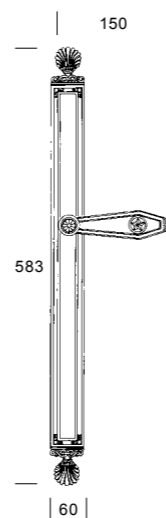

3014/S

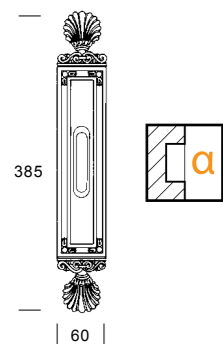

4315/3014

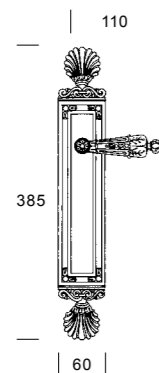



ATENE

Stile: Tardo '700



Stile: Impero



NANCY



3116/3019



3016/S

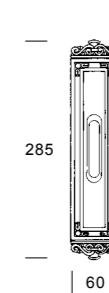

4315/3016

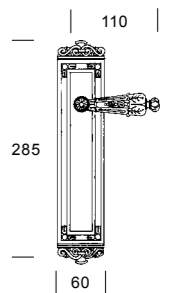



SHARJAH

Stile: Arabesco



Stile: Louis XV



TOURS



3021

| 50 |



| 130 |



| 50 |

3021



| 130 |

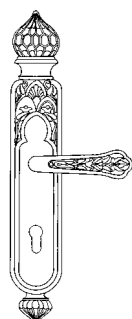

405

| 66 |

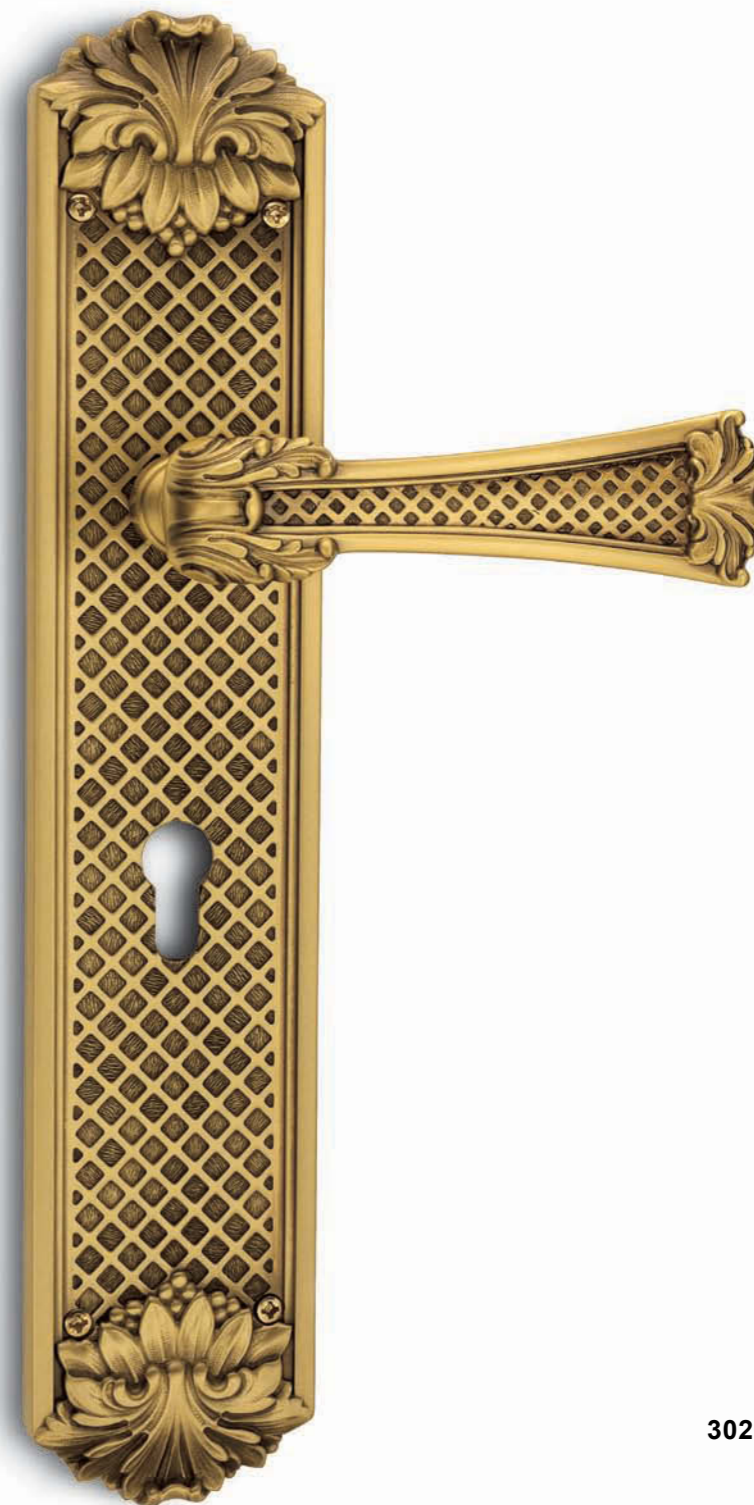

3026



| 140 |

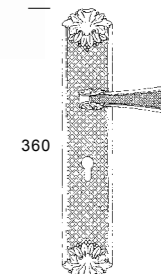

360

| 70 |

| 70 |



ROCHEFORT

Stile: Luigi Filippo - fine 1700



ROCHEFORT



3031

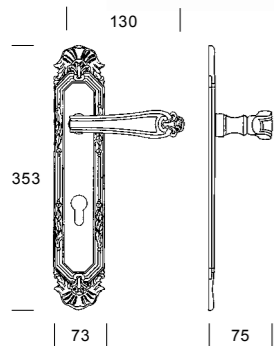

3032



3031/S

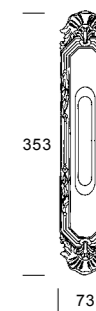



Stile: '700 Spagnolo



LUCCA



3040 

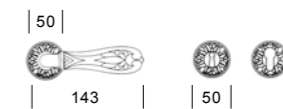

3041 





REIMS

Stile: Louis XV



REIMS



3046



3045

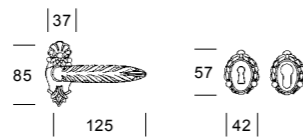

3047

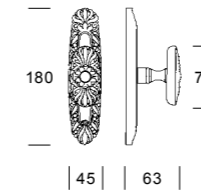

3047/4340







MONTPELLIER

Stile: Chippendale



LUXOR

Stile: Influsso Orientale



3051/S

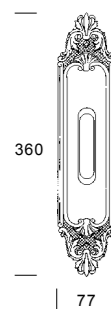

3051

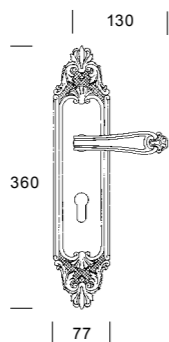

3056

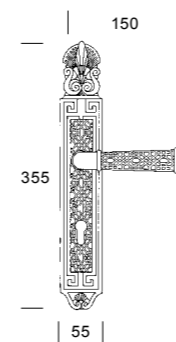

3055

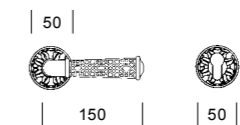



GINEVRA

Stile: Luigi Filippo - fine 1700



3075



| 50 |



| 116 |



| 50 |



GINEVRA



3076



| 116 |

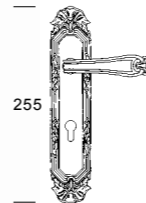

| 255 |

| 53 |



GINEVRA



KIEV



3078/S WC

3078/S CF

3078/S

3076/S

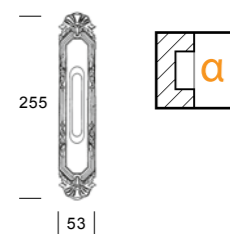

3077/S

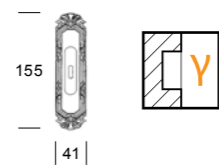

3077/S

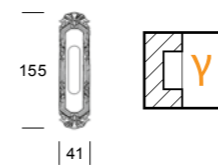



3091

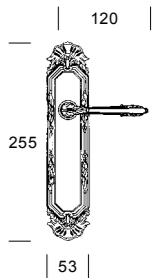

3090

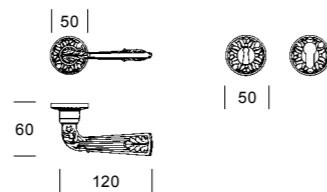



Stile: Luigi Filippo - fine 1700



KING



3096 

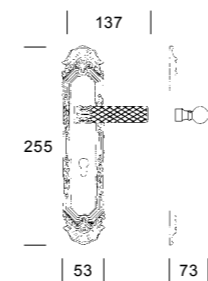

3095 

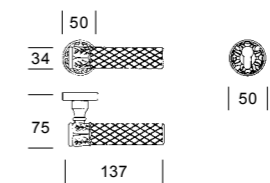



VERSAILLES

Stile: Louis XVI



3100/3001 

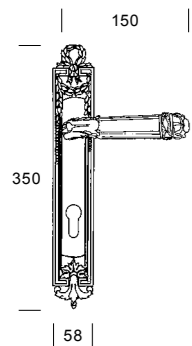

3100/3085 

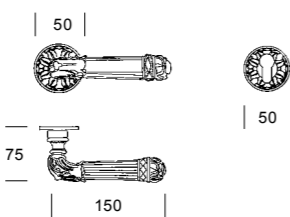

VERSAILLES



3001/S





Stile: Metà '700



PAESTUM



3118 

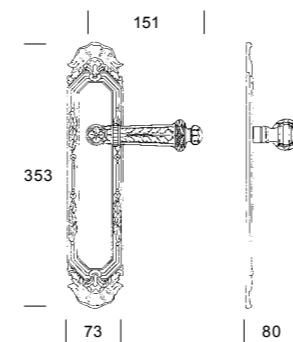

3117 

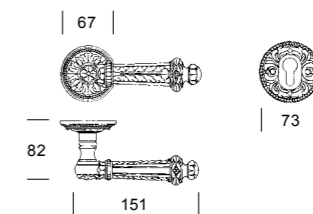



DAKAR

Stile: Riesener



DAKAR



3261 

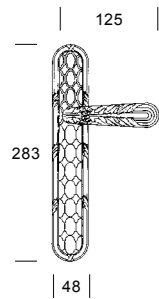

3260 



3262

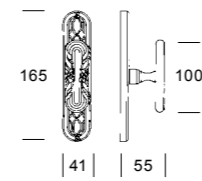

3262/3085

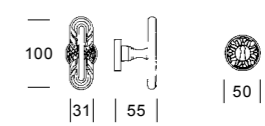



DOHA

Stile: Impero



DOHA



3302



3300

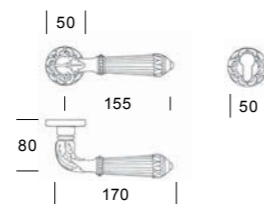

3301





Stile: Impero



NAXOS



3307 



3305 

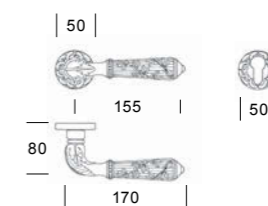



NAXOS



3306 

185

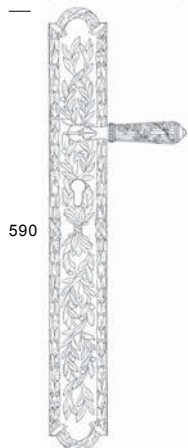

590

78



Stile: Floreale



BAKU



3311 

180

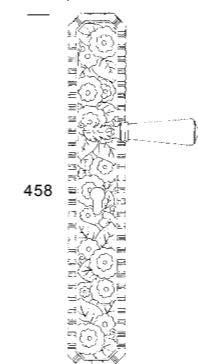

458

73

3310 

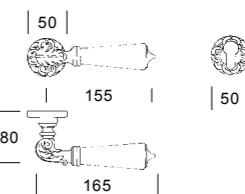

50

155

50

80

165

CAPUA

Stile: Metà 700



Stile: Louis XVI

LILLE

Nuova dimensione
New smaller size

Nuova dimensione
New smaller size



3316

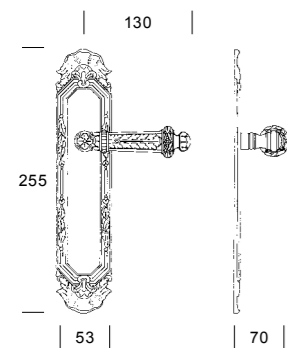

3315

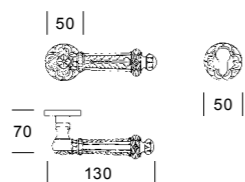

3321

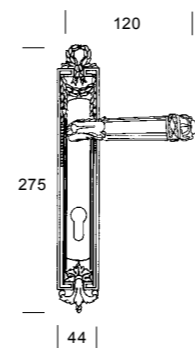

3320

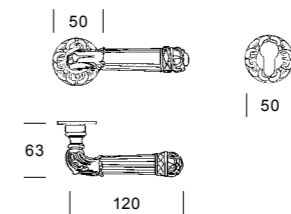





FRESIA

Riccardo Arbizzoni

Stile: Fine 800



FRESIA



3256

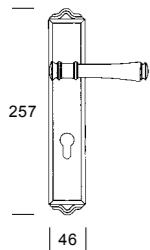

Finiture Finishes

DOR 24K

ETR

OL

D

3255

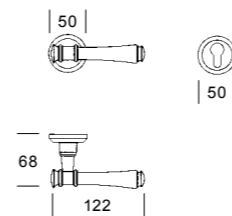

3258/BIS

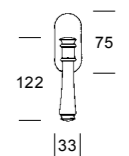

3257

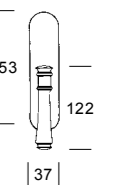



CASSIA

Riccardo Arbizzoni

Stile: Fine 800



CASSIA



Finiture Finishes

DOR 24K

ETR

OL

D

3251

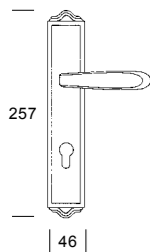

3250

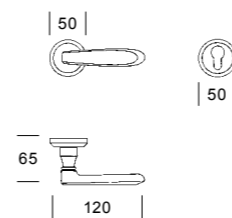

3253/BIS

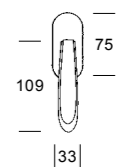

3253

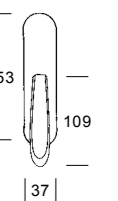





3336 

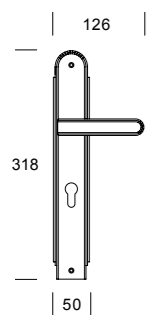

3335 

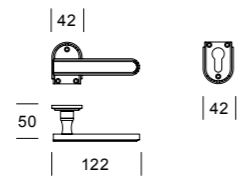

3336/S

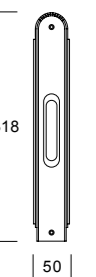



MEDINA

Stile: Art Déco



MEDINA



4206

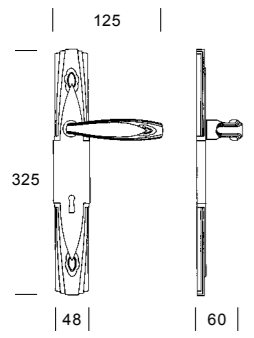

4205

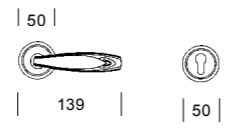

4206/S

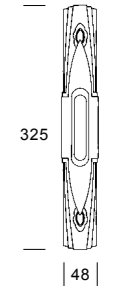





BRUGES

Stile: Louis XV



BRUGES



3331 

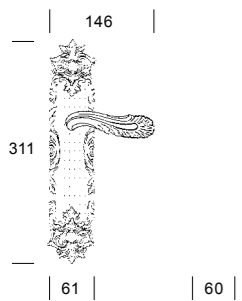

3330 

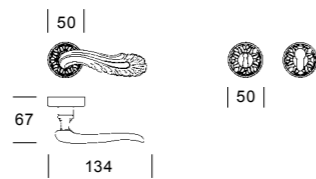

3331/S

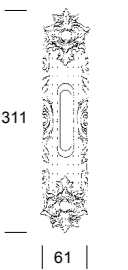



Stile: Barocco



LISBONA



4251

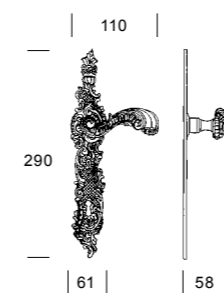

4250

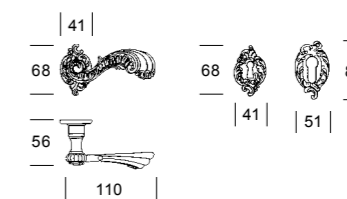

LISBONA



4252

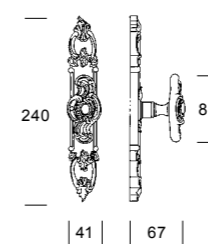

4252/4250

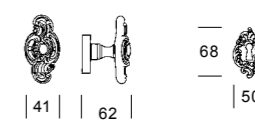



MASQUAT

Stile: Regency



MASQUAT



4256

4255 

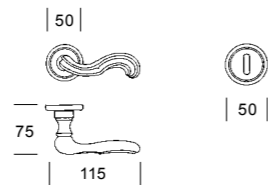
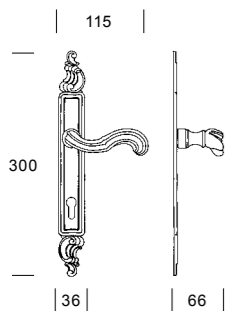

4256/S

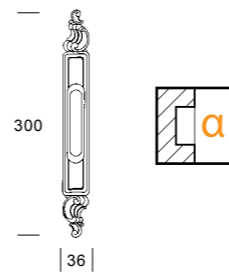

4258

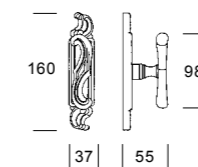

4258/4255

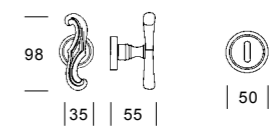



SAMARRA

Stile: Barocco Piemontese



SAMARRA



4271 

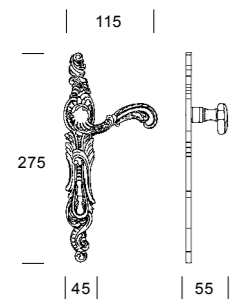

4270

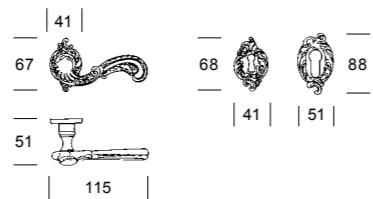

4273

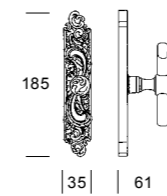

4273/4270

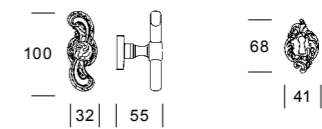





DAMASCO

Stile: Tardo '600



DAMASCO



4286

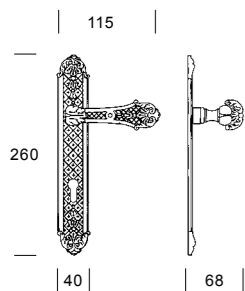

4285

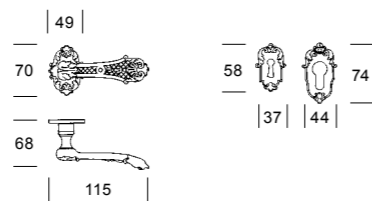

4286/S

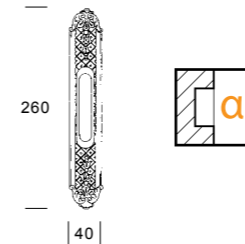

4287

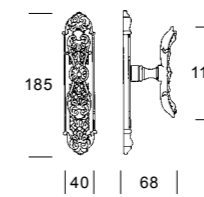

4287/4285

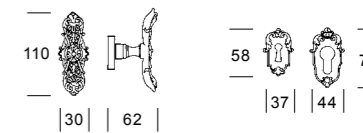



VIENNA

Stile: Louis XVI



4291 

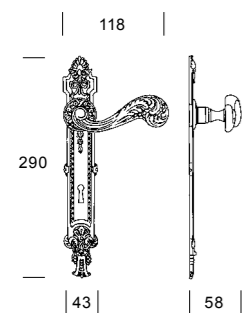

4290

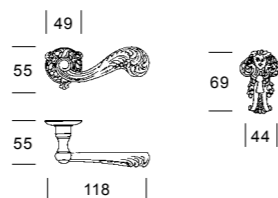

4293

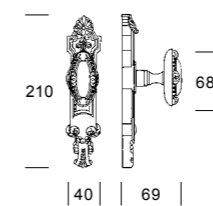

4293/4290



VIENNA



ORLEANS

Stile: Louis XVI



ORLEANS



4296

4295

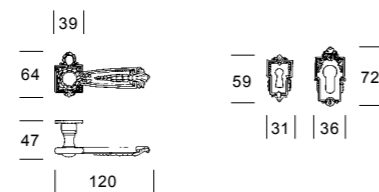
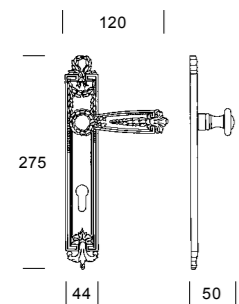

4296/S

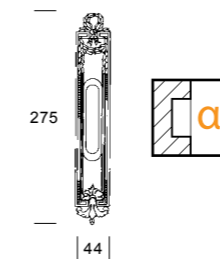

4297/S

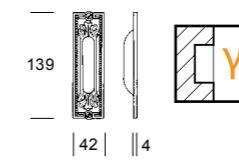

4297

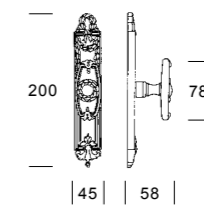

4297/4295





ORLEANS

Stile: Louis XVI



4297



4299/D

Finale
Final piece

4299/B

Cavallotto
Plate for external bars

4299/A

4297/4299A

Pomolo con placca per aste esterne
Knob with plate for external bars

4299/C

Cavallotto
Plate for external bars

4299/D

Finale
Final piece

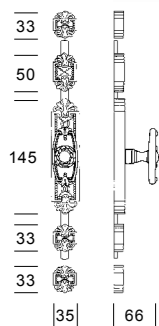



Stile: Louis XVI



LIMOGES



4297



4199/D
Finale
Final piece

4199/C
Cavallotto
Plate for external bars

4199/A

4297/4199A
Pomolo con placca per aste esterne
Knob with plate for external bars

4199/B
Cavallotto
Plate for external bars

4199/D
Finale
Final piece





4295/3006A

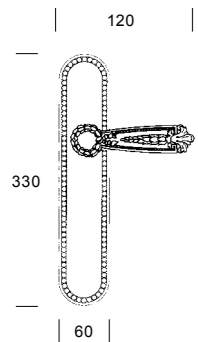

4295/3006B

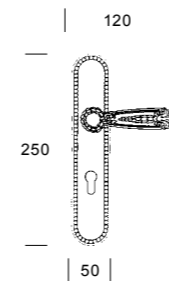

4295/3085

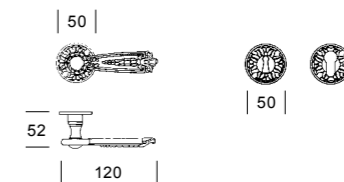



BEIRUT

Stile: Neoclassico



4301 

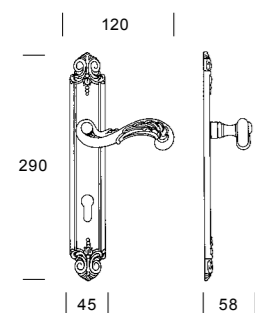

4300

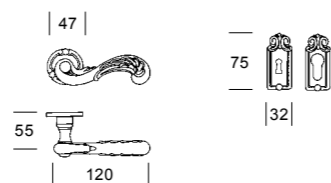

4301/S

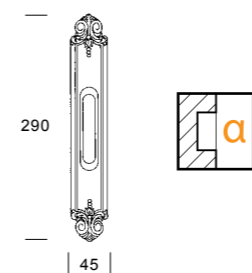

4302

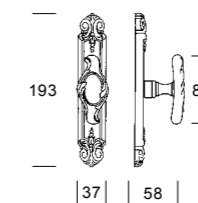

4302/4300

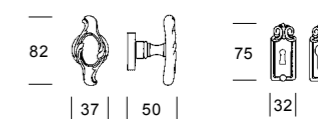

BEIRUT



IL CAIRO

Stile: Secolo XIV



IL CAIRO



4306

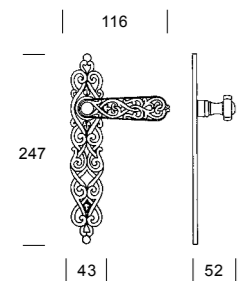

4305

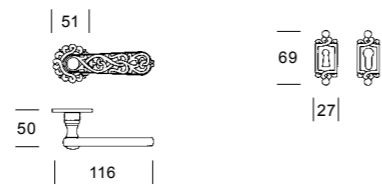

4307

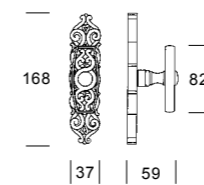

4307/4305

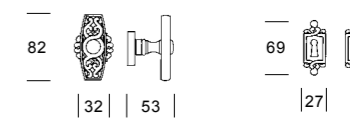



DELHI

Stile: Metà XVII secolo



DELHI



4311

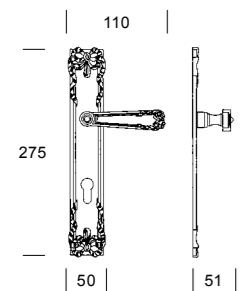

4310

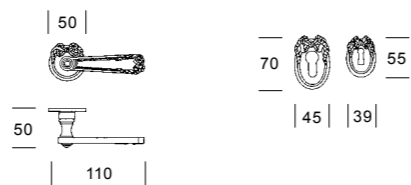

4312

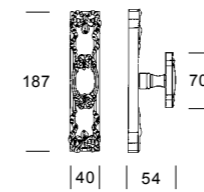

4312/4310

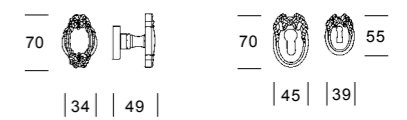



RIYADH

Stile: Arabesco



4311/2

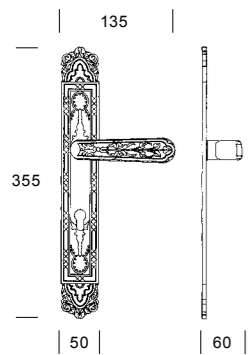



POMPEI

Stile: Impero



POMPEI



4316 

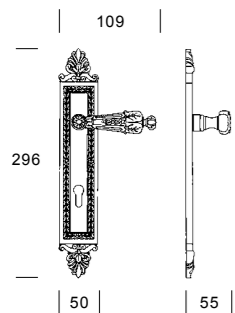

4315

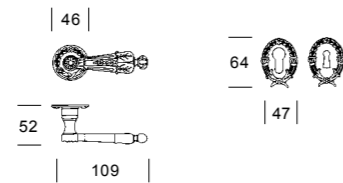

4316/S

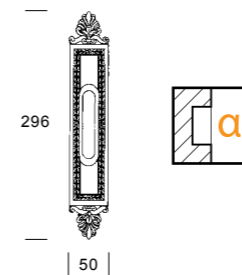

4317

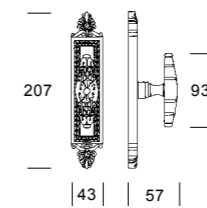

4315/C

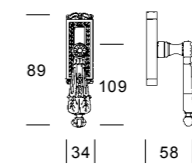

4317/4315

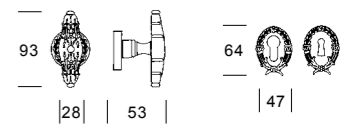





SHANGHAI

Stile: Tardo '700



4331

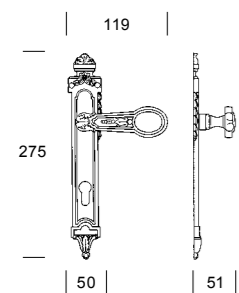

4330

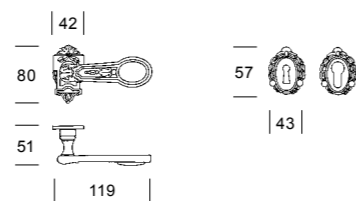

4332

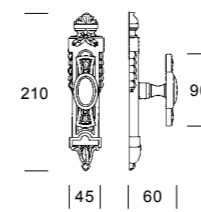

4332/4330

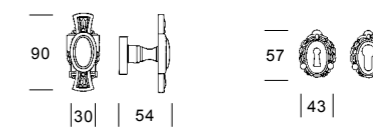

SHANGHAI



JAKARTA

Stile: Louis XV



4336 

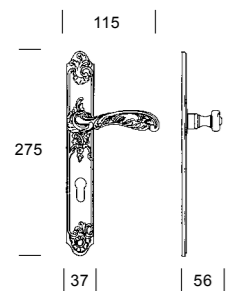

4335



4338

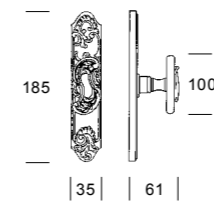

4338/4335

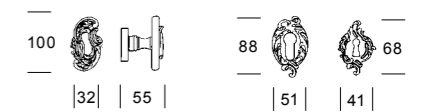

JAKARTA



Stile: Impero



URBINO



4341 

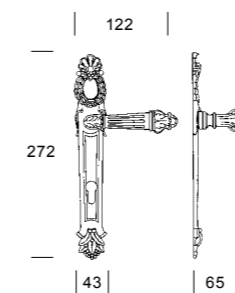

4340

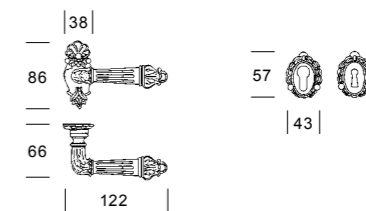

URBINO



4342

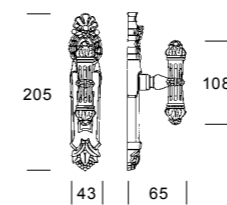

4342/4340

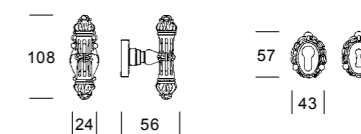



VARSAVIA

Stile: Louis XV



VARSAVIA



4346 

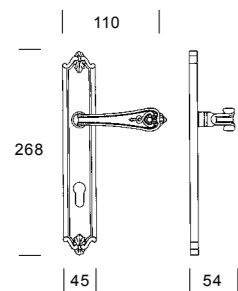

4345

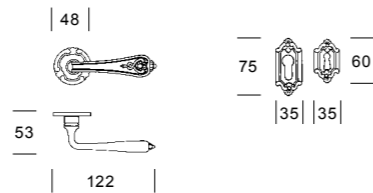

4346/S

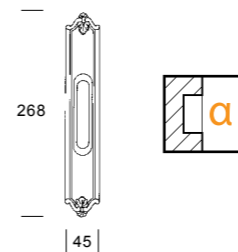

4347

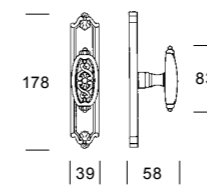

4345/C

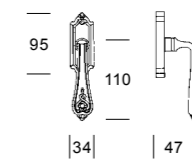

4347/4345

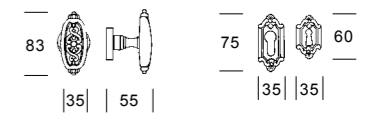



HANNOVER

Stile: Inglese



HANNOVER



4351

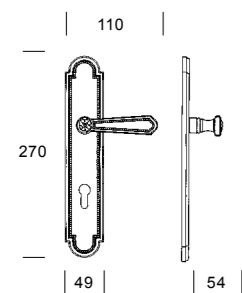

4350

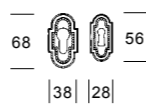
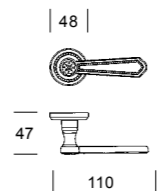

4351/S

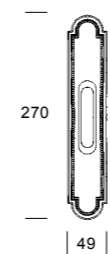

4352

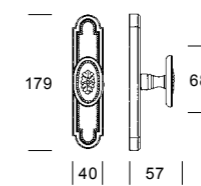

4352/4350

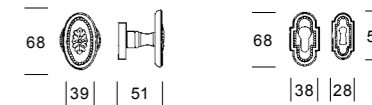



BERLINO

Stile: 700 tedesco



BERLINO



4391

4390

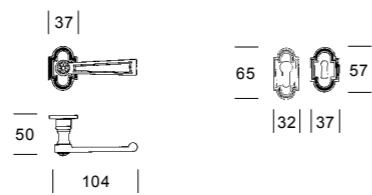

4391/S

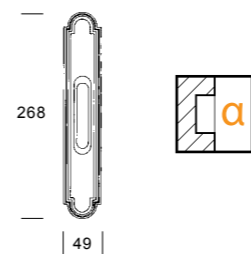

4392

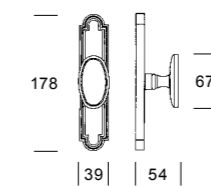

4392/4390

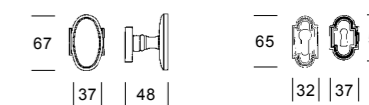



MADRID

Stile: Vittoriano



MADRID



4416

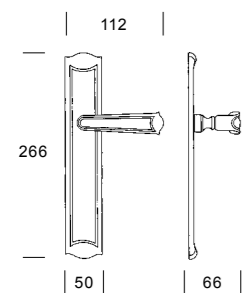

4415

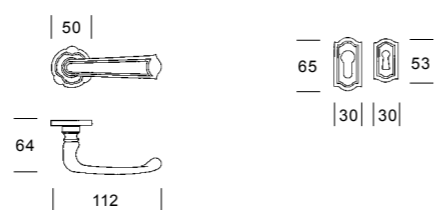

4416/S

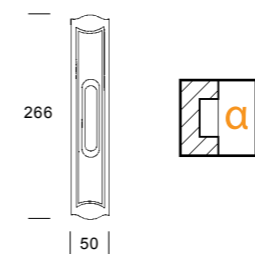

4417

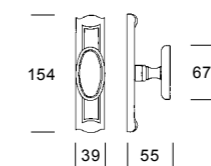

4417/4415

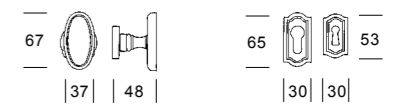



FINITURE FINISHES

**CR**

Cromo
Chrome
Chromé
Cromato
Хром

**CRS**

Cromo satinato
Satin chrome
Chromé satin
Cromato satinado
Сатинированный хром

**GR**

grafite
graphite
graphite
grafito
Графит

**BP**

Black pearl
Блэк перл

**FLA**

Flare

**NL**

nichel lucido
polished nichel
nichel poli
nichel brillo
Блестящая никель

**NS**

nichel satinato
satin nichel
nichel satiné
nichel satinado
Сатинированный никель

**OL**

ottone lucido
polished brass
laiton poli
laton brillo
Блестящая латунь

**PVD**

rivestimento in zirconio
finish in zirconium
revêtement en zirconio
acabado en zirconio
Циркониевое покрытие

**DOR 24K**

bagno oro
gold plated
doré à bain
baño oro
Окунание в Золото

**D**

dorato
gold
doré
dorato
Позолота

**DOR/POV**

bagno oro/patinato oro vecchio
gold plated/old gold
doré à bain/patiné or vieux
baño oro/patinado oro vejo
Старинное золото и патина

**AL/POV**

argento lucido/patinato oro vecchio
polished silver/old gold
argent poli/patiné or vieux
plata brilla/patinado oro viejo
Блестящее серебро/
Старинное золото и патина

**AV**

argento vecchio
old silver plated
argent vieux
plata vieja
Старинное серебро

**B**

brunito
bronze
bruni
brunito
Полировка

**OA**

oro antico 24K
old gold 24K
doré vieux 24K
Alt Gold 24K
dorato viejo 24K
Античное золото 24K

**POV**

patinato oro vecchio
old gold
patiné or vieux
patinado oro vejo
Старинное золото и патина

**AO/POV**

argento opaco/patinato oro vecchio
satin silver/old gold
argent satiné/patiné or vieux
plata satinada/patinado oro viejo
Матовое серебро/
Старинное золото и патина

**BPS**

black pearl satinato
satin black pearl
black pearl satin
black pearl satinado
Блэк перл

**BAS**

brunito satinato
satin bronze
bruni satin
brunito satinado
Сатинированная полировка



FINITURE FINISHES



FINITURE FINISHES

**Z**

Zigrinato
Grained
Moulu
Molido
Шагреновидный

**SB**

Smalto bianco
White enamel
Émail blanc
Esmalte blanco
Белая эмаль

**SBO**

Smalto bianco opaco
Matt white enamel
Émail blanche opaque
Esmalte blanco opaco
Матовая белая эмаль

**SNO**

Smalto nero opaco
Matt black enamel
Émail noir mat
Esmalte mate negro
Матовая черная эмаль

**SA**

Nero sabbia
Black sand
Sable noir
Arena negro
Черный песок

**W**

Noce scuro
Dark walnut
Noyer foncé
Nogal oscuro
Темный орех

**SD**

Smalto daino
Fawn-color enamel
Émail fauve
Esmalte leonado
Эмаль с песочным оттенком

**ST**

Smalto tortora
Dove-color enamel
Émail brun clair
Esmalte de color marrón claro
Эмаль бледно-коричневая с серо ватым оттенком

**28**

Cuoio-Avorio
Leather-Ivory
Cuir-Ivoire
Cuero-Marfil
Сожа-Слоновая кость

**19**

Cuoio-Caffè
Leather-Coffee
Cuir-Café
Cuero-Café
Сожа-кофейный

**02**

Cuoio-Nero
Leather-Black
Cuir-Noir
Cuero-Negro
Сожа-черный



INFORMAZIONI TECNICHE TECHNICAL INFORMATION

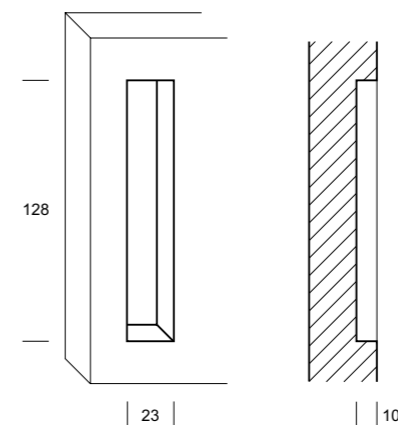

Fresatura maniglia incasso
Milling of fitted handle
Fraisage poignée encastrée
Fraesen Griff Einnahme
Fresado del tirador empotrado
Врезка ручек

